

**CAPITAL UNIVERSITY OF SCIENCE AND  
TECHNOLOGY, ISLAMABAD**



**Impact of Despotic Leadership on  
Deviant Workplace Behaviour:  
Mediating Role of Negative Affectivity  
and Moderating Role of Trait Anxiety -  
A Project Based Organizations  
Perspectives**

by

**Naqeeb Tayyab**

A thesis submitted in partial fulfillment for the  
degree of Master of Science

in the

**Faculty of Management & Social Sciences**

**Department of Management Sciences**

2019

Copyright © 2019 by Naqeeb Tayyab

All rights reserved. No part of this thesis may be reproduced, distributed, or transmitted in any form or by any means, including photocopying, recording, or other electronic or mechanical methods, by any information storage and retrieval system without the prior written permission of the author.

*This work is dedicated to my parents and my  
teachers.*



## CERTIFICATE OF APPROVAL

**Impact of Despotic Leadership on Deviant Workplace  
Behaviour: Mediating Role of Negative Affectivity and  
Moderating Role of Trait Anxiety - A Project Based  
Organizations Perspectives**

by

Naqeeb Tayyab

(MPM171033)

### THESIS EXAMINING COMMITTEE

S. No.	Examiner	Name	Organization
(a)	External Examiner	Dr. Ayesha Noor	SZABIST, Islamabad
(b)	Internal Examiner	Dr. Mueen Aizaz Zafar	CUST, Islamabad
(c)	Supervisor	Mr. Hafiz Muhammad Adnan	CUST, Islamabad

---

Mr. Hafiz Muhammad Adnan

Thesis Supervisor

October, 2019

---

Dr. Sajid Bashir  
Head  
Dept. of Management Sciences  
October, 2019

---

Dr. Arshad Hassan  
Dean  
Faculty of Management & Social Sciences  
October, 2019

## *Author's Declaration*

I, **Naqeeb Tayyab** hereby state that my MS thesis titled “**Impact of Despotic Leadership on Deviant Workplace Behaviour: Mediating Role of Negative Affectivity and Moderating Role of Trait Anxiety - A Project Based Organizations Perspectives**” is my own work and has not been submitted previously by me for taking any degree from Capital University of Science and Technology, Islamabad or anywhere else in the country/abroad.

At any time if my statement is found to be incorrect even after my graduation, the University has the right to withdraw my MS Degree.

**(Naqeeb Tayyab)**

Registration No: MPM171033

## *Plagiarism Undertaking*

I solemnly declare that research work presented in this thesis titled “**Impact of Despotic Leadership on Deviant Workplace Behaviour: Mediating Role of Negative Affectivity and Moderating Role of Trait Anxiety - A Project Based Organizations Perspectives**” is solely my research work with no significant contribution from any other person. Small contribution/help wherever taken has been dully acknowledged and that complete thesis has been written by me.

I understand the zero tolerance policy of the HEC and Capital University of Science and Technology towards plagiarism. Therefore, I as an author of the above titled thesis declare that no portion of my thesis has been plagiarized and any material used as reference is properly referred/cited.

I undertake that if I am found guilty of any formal plagiarism in the above titled thesis even after award of MS Degree, the University reserves the right to withdraw/revoke my MS degree and that HEC and the University have the right to publish my name on the HEC/University website on which names of students are placed who submitted plagiarized work.

**(Naqeeb Tayyab)**

Registration No: MPM171033

## *Acknowledgements*

The task that had begun in 2018 has successfully come to an end. It gives me extreme joy to thank Allah SWT for being so kind towards me through and through. The study comes to completion because of His guidance and blessing.

I would like to extend my deep gratitude towards my parents and my elder brother **Mr. Hafiz Habib Tayyab** who help me through the process of compilation of the research work, towards specially my father who believed in me and who thought I would be able to pursue the degree with other responsibilities of life.

I take huge honor to thank **Mr. Hafiz Muhammad Adnan**, my teacher, my supervisor, who has been available for his assistance and cooperation. He has been quick at responding to queries and confusions. He made sure the thesis was submitted timely and too with the refined quality of the content.

Thank you all!

(**Naqeeb Tayyab**)

Registration No: MPM171033

## *Abstract*

This study examines the relationships between despotic leadership and deviant workplace behaviour with the mediating role of negative affectivity and moderating role of trait anxiety. Data were collected from employees' and their supervisors in different project based organizations from Islamabad Rawalpindi Pakistan. Confirmatory factor analysis confirmed the distinctiveness of variables used in the study. The results of the analysis confirmed that despotic leadership enhances deviant workplace behaviour, while negative affectivity mediates the relationship of despotic leadership between deviant workplace behaviour. This study contributes to the leadership literature in the perspective of affective event theory; since limited attention was paid to the role of despotic leadership as a predictor of deviant workplace behaviour indirectly through negative affectivity and trait anxiety at workplace. Implications of the study are also discussed.

**Keywords:** Despotic leadership, Negative affectivity, Trait anxiety, Deviant workplace behaviour.



# Contents

<b>Author’s Declaration</b>	<b>iv</b>
<b>Plagiarism Undertaking</b>	<b>v</b>
<b>Acknowledgements</b>	<b>vi</b>
<b>Abstract</b>	<b>vii</b>
<b>List of Figures</b>	<b>xi</b>
<b>List of Tables</b>	<b>xii</b>
<b>Abbreviations</b>	<b>xiii</b>
<b>1 Introduction</b>	<b>1</b>
1.1 Background . . . . .	1
1.2 Gap Analysis . . . . .	4
1.3 Problem Statement . . . . .	6
1.4 Research Questions . . . . .	7
1.5 Research Objectives . . . . .	7
1.6 Significance of this Study . . . . .	8
1.6.1 Theoretical Significance . . . . .	8
1.6.2 Practical Significance . . . . .	8
1.6.3 Contextual Significance . . . . .	9
1.7 Key Terms and Definitions . . . . .	10
1.7.1 Despotic Leadership . . . . .	10
1.7.2 Workplace Deviant Behavior . . . . .	10
1.7.3 Negative Affectivity . . . . .	10
1.7.4 Trait Anxiety . . . . .	10
1.8 Supporting Theory . . . . .	11
<b>2 Literature Review</b>	<b>12</b>
2.1 Despotic Leadership and Deviant Workplace Behavior . . . . .	12
2.2 Mediating Role of Negative Affectivity between Despotic Leadership and Workplace Deviant Behaviors . . . . .	22

---

2.3	Moderating Role of Trait Anxiety . . . . .	30
2.4	Theoretical Framework . . . . .	32
<b>3</b>	<b>Research Methodology</b>	<b>33</b>
3.1	Research Design . . . . .	33
3.1.1	Study Type . . . . .	33
3.1.2	Study Setting . . . . .	34
3.1.3	Time Horizon . . . . .	34
3.1.4	Research Interference . . . . .	34
3.1.5	Unit of Analysis . . . . .	34
3.1.6	Data Collection Process . . . . .	34
3.2	Population and Sampling . . . . .	35
3.2.1	Population . . . . .	35
3.2.2	Sample and Procedures . . . . .	35
3.3	Scales . . . . .	35
3.3.1	Despotic Leadership . . . . .	36
3.3.2	Negative Affectivity . . . . .	36
3.3.3	Workplace Deviant Behaviors . . . . .	36
3.3.4	Trait Anxiety . . . . .	37
3.4	Measures . . . . .	37
3.5	Reliability . . . . .	38
3.6	Sample Characteristics . . . . .	38
<b>4</b>	<b>Data Analysis and Results</b>	<b>40</b>
4.1	Descriptive Statistics . . . . .	40
4.2	Control Variables . . . . .	41
4.3	Confirmatory Factor Analysis . . . . .	42
4.3.1	Alternate Competing Models . . . . .	44
4.4	Correlation Analysis . . . . .	45
4.5	Regression Analysis . . . . .	46
<b>5</b>	<b>Discussion, Implications, Limitations, Recommendations and Conclusion</b>	<b>51</b>
5.1	Discussion . . . . .	51
5.1.1	Discussion on Research Question No. 1 . . . . .	52
5.1.2	Discussion on Research Question No. 2 . . . . .	54
5.1.3	Discussion on Research Question No. 3 . . . . .	57
5.2	Implications and Recommendations . . . . .	59
5.2.1	Theoretical Implications . . . . .	59
5.2.2	Practical Implications . . . . .	60
5.3	Limitations . . . . .	62
5.4	Conclusion . . . . .	63
	<b>Bibliography</b>	<b>64</b>



# List of Figures

4.1	CFA, full measurement model (AMOS 20 output) . . . . .	43
4.2	Moderation graph. . . . .	49

# List of Tables

3.1	Scale Reliabilities. . . . .	38
3.2	Respondents' demographic characteristics. . . . .	39
4.1	Descriptive Statistics (Minimum, Maximum, Mean and Standard Deviation). . . . .	40
4.2	Control variables (ONE WAY ANOVA). . . . .	42
4.3	CFA Results (Four factor solution). . . . .	42
4.4	CFA Results. . . . .	44
4.5	Correlation Analysis. . . . .	45
4.6	Regression Analysis for Direct Effect on deviant workplace behavior. . . . .	47
4.7	Regression analysis for Mediation. . . . .	48
4.8	Regression Analysis for Moderation. . . . .	49
4.9	Summary of Hypotheses. . . . .	50

# Abbreviations

<b>CEO</b>	Chief Executives Officer
<b>DD</b>	Dogmatic Deviance
<b>DL</b>	Despotic Leadership
<b>DWB</b>	Deviant Workplace Behaviour
<b>NA</b>	Negative Affectivity
<b>OCB</b>	Organizational Citizenship Behaviour
<b>PA</b>	Personal Aggression
<b>PD</b>	Production Deviance
<b>SD</b>	Stuff Deviance
<b>TA</b>	Trait Anxiety

# Chapter 1

## Introduction

### 1.1 Background

Organizations of today are moving forward at fast expression than ever and their environment is becoming more and more complex with passage of time. For the last several years, environmental forces in the business domain (global competition and economic situation etc.) have involved challenging demands for organizations and its employees. The challenging demands are transformed to work environment whereby existence of negative behaviors and interpersonal exploitation are very common these days (Sakurai & Jex, 2012). Organizations today are therefore more concerned than ever, for how to alleviate the impact of interpersonal stressor and their corresponding negative consequences at work (Stamper & Johlke, 2003).

The gloomy sideways of leadership is a vital exploration subject, mainly in bright of shared gossips such as those at WorldComs and Enron (Naseer et al., 2016). Autocratic governance permits concern in specific, owing to its resilient possible to utilize negative things on both private and organizational results (De Hoogh & Den Hartog, 2008; Naseer et al., 2016).

The general study that statements management in organizations mostly emphasizes on positive features quite than despotic leader behaviors (Raja et al., 2019; Andersson & Pearson, 1999; Schilling, 2009). An inherent statement in this study is that inadequate leadership is correspondent to a absence of management, but collective

perceptions into the dark side of negative leadership in organizations challenge this theory (Naseer, Raja, Syed, Donia, & Darr, 2016). Despotic leadership is not just the deficiency of active leadership abilities; relatively, it suggests behaviors that hurt admirers, including fraud, evidence falsification, management, and illegal acts (Schyns & Hansbrough, 2010). Between the numerous types of damaging leadership (Schilling, 2009), tyrannical management in specific has been inadequately discovered (Naseer et al., 2016). A dictatorial manager involves in controlling, regulatory activities to attain his or her egotisms, as well as self-aggrandizing and fraud of juniors (Aronson, 2001). Such managers are autocratic and higher, and they accept wrong codes of behavior. Because of their likely to mischief single well-being and presentation, which straight decides organizational enactment (De Hoogh & Den Hartog, 2008; Naseer et al., 2016), dictatorial managers need more research care. In certain, we want visions into how it utilities for organizations in rising countries, particularly those clear by high power space and collectivism.

To address these gaps, we explore the harmful effects of despotic leadership on employees' performance, pleasure and well-being in Pakistan. Despotic leadership may be especially relevant and contextually significant for cultures that tend to be collectivistic, collective and marked by high power distance (Hofstede, 2007).

Workers' Islamic work ethics also capacity stimulate the adverse liaison among workers' contact to autocratic leadership and their job routine, job self-actualization and emotional well-being. An Islamic work ethics reveals ethical morals fixed in Islam, which separate what is true from what is incorrect (Beekun, 1997). As stated, an worker with a solid Islamic work ethics identifies the workplace as a apartment for cooperation, pledge and tough work (Ali, 1992) and emphasizes her or his optimistic supports to a outgoing workplace atmosphere in which she or he achieves mandatory job accountabilities (Khan et al., 2015).

To represent the negative side of the leadership certain other terms have been used like (Ashforth, 1994) called it petty tyranny Tepper, (2007) said it to be the abusive supervision and (Einarsen et al., 2007) named it destructive leadership then (Aronson 2001) called it to be the Despotic leadership. (House and Howell, 1992) and (Naseer et al., 2016) is of the view that despotic leadership is exercised



by a leader who has the thirst of attaining authority and supremacy. He is led by the egotisms they are factually scheming, superior, dominant, obstinate and hard with inflexible attitude. (Schilling 2009) says that despotic leadership brings most of the negative potentials of leadership. Even though in the area of political leadership it has been discussed strongly however in the broad management and applied psychology it is in primary stage.

Negative affectivity has formerly been clear as a constant attribute that returns the trend to skill negative feeling and grief across situations and even in the time off of objective stressors (Watson & Clark 1984, Watson et al. 1987). It has remained discussed by some professional strain researchers that negative affectivity may develop associations between self-reported stressors and anxiety, so operative as a applied distress (Brief et al. 1988). Not startlingly, significant research and debate has been created over the practical irritant properties of negative affectivity (Brief et al. 1988, Burke et al. 1993, Chen & Spector 1991, Jex) and (Spector 1996, Schaubroeck et al. 1992).

Offensive administration has been reflected as potential initiator of counterproductive work behaviors (Tepper et al. 2009). Further employee's deviance has been shown as hot effective response to negative forces at workplace. Based on the opinions cited above it can be debated that despotic leadership may lead to workplace deviant behaviors and therefore it is assumed that:

Social deviant behaviors are fixed at fellow workers and include actions like making fun of someone passing some racial, racial or religious clarifications, playing a mean joke, passing horrible or painful remarks, behaving with vulgarity or freely embarrassing a teammate. Deviances at Organizational levels are targeted at the work domain in sum, consist of actions such as thieving, making longer than accepted work breaks, and coming late without permission, using an unlawful drug at work and withholding effort (Bennett & Robinson, 2000).

If trait anxiety is associated with underprivileged active acceptance of prefrontal control tools to run the circulation of commitment when it is not fully enforced by the mission at hand, then we would forecast that this would be detected under such situations: that is, by way of a purpose of reaction conflict under circumstances

of low, but not high, perceptual capacity. While trait anxiety has been proved to be negatively related with the prefrontal reaction to threat-related distractors under related conditions it is not potential to launch whether interference to cortical intentional tools is minor to developed subcortical quickly to threat-related stimuli or vice versa with the attention-to-threat system that was used. A process that influences the need to exert responsiveness control in response to changes in treating struggle in the presence of threat-related stimuli is compulsory to avoid this problem.

## 1.2 Gap Analysis

Abusive supervision (a form of Despotic leadership) has been reflected as prospective originator of counterproductive work behaviors (Tepper et al., 2009). Further employee's deviance has been shown as hot effective response to negative forces at workplace. Based on the arguments mentioned above it can be argued that Despotic leadership may lead to workplace deviant behaviors and therefore it is hypothesized that:

Research investigating the negative impact of interpersonal mistreatment at work have shown that Abusive supervision threaten employees react through deviant behaviors (Kluemper et al., 2018). Defeat has been found a source of harmful behavior (Fox and Spector, 1999) and continuous victimization has also been found to create retaliatory behavior and workplace deviant behaviors (Kluemper et al., 2018). Relational aggression was found highly associated with deviant behavior at workplace (Hershcovis et al., 2012). Although previous research has shown association between other forms of interpersonal mistreatment with deviant behaviors, limited attention has been paid to relationship of despotic leadership with workplace deviant behaviors.

Workplace deviant behaviors include planned acts and counterproductive behaviors that disrupt organizational norms and endanger the wellbeing of its members (Robinson and Bennett, 1995). Previous research on Workplace deviance has mainly focused on the situational factors (working climate, supervisory behaviors)

and limited attention has been paid to the individual characteristics (Kluemper et al., 2018). Further employee's deviance has been shown as hot effective response to negative forces at workplace. Based on the arguments mentioned above it can be argued that despotic leadership may lead to workplace deviant behaviors.

Previous research on despotic leadership-outcome relationship has shown that affective responses (emotions) are prospective mediators and pivotal to understanding the harmful effects of despotic leadership. (Rai & Agarwal, 2017) and negative emotions are converted to unwanted attitude & behaviors. The consistent and longitudinal actions of bullying are translated to high level of negative emotions which resultantly lead to detrimental outcomes for the exposed victims (Ursin and Eriksen, 2004). The consistent negative behaviors of perpetrator tends to produce negative affect in victims and more susceptible individuals respond with enhanced negative emotional states, and are thus more vulnerable physical sickness (Watson, 2000) and the victims generally are found with enhanced stages of negative effect (Coyne et al., 2000, 2003; Glaso et al., 2007).

Negative affectivity is explained as the personal propensity to sense different of negative affective states generally characterized by sentiments that include nervousness, dread, sorrow, and annoyance (Watson & Clark, 1984). Individuals who are characterized scared, anxious and sad are more prone victims to possible perpetrators (Samnani and Singh, 2012). It has been argued that experience of undesirable events can add significantly to negative affectivity. However very little attention been paid by research, studying the emotional state of negative affectivity in relationship to Despotic leadership and /or deviant behavior as outcome.

Previous research studies have also recognized that individual differences play pivotal part in helpful and formative at workplace ,therefore it is argued that personal dispositional traits can be considered as moderator within the association of despotic leadership with outcomes (Moreno-Jimenez et al., 2009).In this perspective one of the key personal characteristic Trait anxiety has gained very less attention in despotic leadership research , besides other dispositional features (aggressiveness, efficacy, anger, anxiety, etc ) have been studied as moderating in the Despotic–outcome relationships (Rai and Agarwal, 2017).

Anxiety is considered to be the “important occurrence and the significant problem of reservation” (Freud, 1936, p. 85), and it is approximately observed as the “most persistent emotional occurrence of our time” (Hoch & Zubin, 1950). Not single is anxiety a basic thought in most recent philosophies of character, but the universality of anxiety phenomena is also openly revealed in literature, the arts, religion and numerous other facets of existing life. Hence, it would seem that multicultural research on anxiety strength be especially productive in paying to a more broad understanding of human nature.

The word “anxiety” is also castoff to refer to specific transformations in anxiety-proneness as a personalities trait. Those who are high in trait anxiety are more intensely disposed to apparent anxiety conditions than are persons. Neurotic personalities, for example, are high in A-Trait and more expected to respond to situations that include threats to self-assurance with greater advancements in A-State concentration than persons who are low in trait anxiety. Neurotics also have a better inclination to anxiety than non-neurotics, even in surroundings where there is little or no outside stress.

Based on these facts, arguing that despotic behaviors in the form of negative consistent events are related to emotional state, negative affectivity may act as mediator in the relationship between despotic and deviant behaviors at workplace. Given the fact that cognitive capabilities have been found as influencer of deviant behaviors to supervisory mistreatment (Kluemper et al., 2018), we assume that trait anxiety will moderate the impact of despotic leadership, resulting in lower negative affectivity and subsequent deviant behaviors at workplace.

### **1.3 Problem Statement**

Research on despotic leadership-outcome relationship has gained much attention over a period of time. Understanding of behavioral outcomes is of practical importance to organization. It is evident that behavior is result of affective and cognitive appraisal, with supplementing role of personality, an integrative assessment of such mechanisms is essential to the study of despotic leadership. Since

despotic leadership has multifold effects for organization and its employees, extensive research is needed as guided by researcher. Previous studies have stressed that despotic leadership results in negative emotional states and parallel negative behaviors of the victims. Explaining the relationship of despotic leadership with undesirable emotional and subsequent detrimental workplace behavior is of particular importance as it provides a rational path for understanding the concept in depth. The present study is therefore, conducted to frame these are variables for investigating how despotic leadership will cause workplace deviant behaviors and within the framework to see the role of negative affectivity as mediator and the role of individual's trait anxiety as moderator. Moreover, the focus of the study are employees of public sector organizations in Pakistan.

## 1.4 Research Questions

On the basis of above cited arguments and problem statement, the current study intends to find answers for following questions:

**Question 1:** Does despotic leadership affect workplace deviant behaviors of employees?

**Question 2:** Does negative affectivity mediates the relationship between despotic leadership and workplace deviant behaviors?

**Question 3:** Does trait anxiety moderates the relationship between despotic leadership and Negative Affectivity?

## 1.5 Research Objectives

- To examine and understand the relationship between despotic leadership and workplace deviant behaviors.
- To examine and understand the mediating role of negative affectivity within the relationship of despotic leadership and workplace deviant behaviors.

- To examine the moderating role of Trait Anxiety between despotic leadership and Negative Affectivity
- To offer significant implications for theoretical understanding and managerial practices based on findings of the study.

## 1.6 Significance of this Study

### 1.6.1 Theoretical Significance

This study will contribute to research and literature on despotic leadership-outcome relationship in several important ways. First despotic leadership has been studied with several outcomes, however, as highlighted earlier limited studies are available related to behavioral outcomes and workplace deviant behavior is a new area of study and contribution of our proposed investigation. Second, emotional states have been studied earlier as mediating factor in despotic outcome relationship, however negative affectivity as an emotional state has not been studied earlier, therefore this study will contribute as how despotic leadership effect negative affectivity of the victim. Finally, our study will contribute by investigating the integrative framework, comprising of despotic leadership – deviant behaviors relationship under the moderating effect of trait anxiety as personal trait which has not been studied jointly by earlier research in the context despotic leadership.

### 1.6.2 Practical Significance

The current study can be seen importantly for its practical significance. Assessment and development of the personal capacities of individuals are major aspects of managerial vision from human resource functional perspective. Investigating and establishing the fact that employee with low level of internal locus of control under the state of enhanced negative affectivity are more prone to negative impacts of despotic leadership this study is of particular importance and have several managerial implications. For instance organization may imply the yardstick

of personal traits by assessment through psychological evaluation, while selecting potential candidates for employment as per nature of job and working environment. Organization may also take up several interventions strategies and advance level training programmes for employees to develop their personal capabilities of handling negative experiences and behaviors(Rai and Agarwal, 2017). Literature also elaborated the situational factors that strength or weeken the relationship in specific environment with in specific event to behaviour relationship (De Hoogh & Den Hartog, 2008). Some more variables is supposed in project based organizational policy that exemplifies such an worker's single calculation of those ranking to which the project based organizational surroundings is managerial (Ferris, Harrell-Cook, & Dulebohn, 2000; Harrell-Cook, Ferris, & Dulebohn, 1999).

In addition, that chief executive officers in project-based organization chief in the earning-based organization noted more on social responsibilities and its feature duty related with others and personal judgment. These results are in link with impression that manager that possible to linked to the project based organization that need and suite to their personality(Schneider, 1987; Schneider, Smith, Taylor, & Fleenor, 1998; Turban & Keon, 1993).People are at more stress for theirs role and responsibilities that may high involvement and more possible different jobs in non profit organization as these organization need social and moral responsible direction and smoothly driven.

### 1.6.3 Contextual Significance

The present study is of particular importance in Pakistani context as limited studies are available in general about despotic and specifically, we found less study related to the integrative proposed model of despotic leadership, given the dimensions of negative affectivity and trait anxiety.

## **1.7 Key Terms and Definitions**

### **1.7.1 Despotic Leadership**

Between the numerous types of negative leadership (Schilling, 2009), despotic leadership in specific has been too little explored (Naseer et al., 2016). A despotic leader contains in controlling, governing behaviors to complete his or her self-interests, as well as self-aggrandizing and fraud of juniors (Aronson, 2001). Such leaders are authoritarian and superior, and they accept bad codes of manner. Because of their likely to harm specific well-being and enactment, which directly concludes organizational performance (De Hoogh & Den Hartog, 2008; Naseer et al., 2016), despotic leaders need further research care. In specific, we need visions into how it utilities for organizations in developing countries, especially those marked by high power distance and collectivism.

### **1.7.2 Workplace Deviant Behavior**

Workplace deviance comprise of intentional acts and counterproductive behaviors that disrupt organizational norms and endanger the wellbeing of its members (Robinson and Bennett, 1995).

### **1.7.3 Negative Affectivity**

Negative affectivity is explained as the personal tendency to sense different of negative affective states generally characterized by ideas that include nervousness, dread, sorrow, and annoyance (Watson & Clark, 1984)

### **1.7.4 Trait Anxiety**

Anxiety is measured to be the “important phenomenon and the significant problem of reservation” (Freud, 1936, p. 85), and it is extensively viewed as the “most general emotional occurrence of our time” (Hoch & Zubin, 1950). Attribute Anxiety



(Spielberger, et al., 1970) was clarified into Spanish with the help of psychologists from 10 different Latin American countries. The term “anxiety” is also used to refer to individual transformations in anxiety-proneness as a personality trait.

## 1.8 Supporting Theory

The underpinning theory that support our proposed model is Affective Event theory (AET). AET postulates that work actions and environment affect the sentiments of employees and these feelings further lead them to perform and counter (Weiss & Cropanzano 1996). According to this theory Work environment provides the platform where attitudes are influenced through affective path, thus hassles and uplifts are translated to either positive or negative affective responses, which resultantly lead to corresponding negative or positive behaviors. Hence it's obvious that any component or action of the environment within work domain has positive or negative implication on corresponding emotions and subsequent behavior. AET describes that experience of working condition (e.g. despotic behaviors) impact affective states and resultant behaviors. According to AET, affective experiences are central in the linkage of outcome with their corresponding work events i.e. Despotic leadership (Glaso and Notelaers, 2012).

Grounded on AET, we argue that Despotic leadership encompasses actions and events wherein employees are treated unfairly and inappropriately, hence such actions may enhance negative affectivity of the Despotic leadership. In such poisoned interpersonal environment, the target of despotic will feel hurt, sad and anxious and therefore may engaged in deviant work behaviors. Their tendency of pro-organizational positive behaviors may be reduced and they may act inappropriately. Further as agued by AET, personality traits have substantial effect in defining the relationship of workplace actions with corresponding emotional states and behaviors.

# Chapter 2

## Literature Review

### 2.1 Despotic Leadership and Deviant Workplace Behavior

Especially for the most portion at risk leader did not indicate high authority sharing conduct (component of moral administration) as evaluated by subordinates. Rather, the type of organization spoken to by the chief executive officers CEOs was build up to be progressively significant for the presence of this leader behavior.

Many organization that was fond important in relationship in Despotic leadership. Mainly chief executive officer in the authority of non profit organizations that compared to chief executive officer in developing sector or profit sector were recognize more power or authoritarian disbursement leadership as compared to despotic leadership. Although finding are in combine with the suggestions that future organization have a tendency to fellow as personal gaining philosophy focusing the transfer of power although upper management in profit based organization considered reliable authority over combine resources (Knoke & Prensky, 1984).

Numerous studies have seen into leader-related thoughts, mostly follower clash to the leader (Bligh et al., 2007) and attitudes towards the managers (Ashforth, 1997). The statement is that followers show conflict headed for negative leaders. Tepper, Duffy, & Shaw, (2001) argue that resistance such as ignoring demand can

be a way of ongoing leaders in a manner that “is rather unclear from the target’s viewpoint in terms of determined” and therefore a noble way to strike back to leaders. Their outcomes check that rude command is positively related to conflict. With respect to approaches headed for leaders, an example is (Duffy & Ferrier’s, 2003).

The appearance of leadership holds in single capacity to show authority on others just subordinates to help gain organization objectives. In hence its growing the field of leadership has been perfect focusing the special effects of leadership on their subordinates and organization (Schilling, 2009), although particularly avoiding the dark side of the leadership (Naseer et al., 2016). Although previous few decades have seen a smooth growth in the works on the theoretically blackface of leadership (Naseer et al., 2016). Increasing interest in the some parts of leadership mentioned a main example (Karakitapoğlu-Aygün & Gumusluoglu, 2013) that identifies the bad effect that leaders can impose on their juniors.

The main research that statements leadership in project based organization mainly applied on positive side other than gloomy leadership behaviors (Usman raja et al., 2019; Andersson & Pearson, 1999; Schilling, 2009). An define argument in research is that failed leadership is similar to lack of leadership but collective vision in to the black side of negative leadership in project based organization challenges that statement (Naseer, Raja, Syed, Donia, & Darr, 2016). Bad leadership is not a simply the absence of effective leadership qualities rather then it implies manners that hurts the subordinates having fraud falls statements, influence in criminals acts (Schyns & Hansbrough, 2010).

Among various types of negative leadership in project based organization (Schilling, 2009), despotic leadership in particular has been too small explain (Naseer et al., 2016). A autocratic leaders including in controlling, running behaviors to achieve their self interest as well as self aggrandizing bad behaviors to their subordinates (Aronson, 2001). That leaders are despotic fulfill and adopt dishonorable codes of conduct. Because of their potential to hurt some well being and performance, which focused on project based organization and their achievements (De Hoogh

& Den Hartog) despotic leader need up to date research consideration. In generally they need abilities in to how it gain for organization in developing countries generally that who clear by high power distance and collectivism.

The dark side of boss in project based organization is an important research topic generally in light of business scandals (Naseer et al., 2016). Autocratic leadership deserve and considered in particular due to high power to imposed harmful effects on both individual and organization results (De Hoogh & Den Hartog, 2008; Naseer et al., 2016)in project based organization leader generally focused on main goals but some time leader imposed power on subordinate to deal them as autocratic manners.

In relationship with focusing attention in the dark side of the leadership arguments have been projected to chase this hypothesis with important autocracy (Ashforth,1994), rude administration (Tepper, 2000),manager disheartenment (Duffay, Ganster, & Pagon, 2002),autocratic leadership, destructive leadership (Einarsen, Aasland, & Skogstad, 2007; Schyns & Hansbrough, 2010), Discourteous leadership (Aronson, 2001). Autocratic leadership refers to the leader action that attains power and authority and that reflect by leader personal interest those leades are more acceptable controlling bossy and challenging (Bass, 1990; House & Howell, 1992; Howell & Avolio, 1992; McClelland, 1975). According to (Schilling 2009), Autocratic managers is a extend example that includes the main important feature of negative leadership types however although established presence in the administrative leadership theoretical as wel as natural demand research in this era in the broad management and applied perception theoretical is still in its starting.

Lot of research has been paid attention on the negative leadership style e.g. tyrannical leadership, followers optimism and emotions of workers in a specific leadership style (De Hoogh & Den Hartog, 2008). Previous research investigative the negative relationship between tyrannical leadership and followers' optimism and sensitivities of a leader's efficiency shows conflicting findings (De Hoogh & Den Hartog, 2008).

The occurrence of leadership contains an individual's skill to affect others followers to help achieve organizational intentions. Since its footing, the field of leadership

has been romanticized, highlighting the helpful effects of leaders on factions and organizations (Schilling, 2009), while basically neglecting the dark side of leadership (Naseer et al., 2016).

In addition, this study explores value similarity as the boundary condition for organizational identification, i.e. the organizational deviance liaison. Existing theories and research indicate that leadership and worth similarity significantly effect individual workplace deviance (e.g. Brown and Treviño, 2006; Tepper et al., 2009).

Character models developed high significant in circumstances of great indecision so that uncertainty in which characters be disposed to trust extra on public judgment person as a tool of instructive evidence. Therefore, perceiving character representations assistances entities to make intellect of the indication they are unprotected to habitual which they that put away to sort analyses around theirs own competence and anticipated equal of presentation. It is dynamic for organizations to that conscious of that standards of discounting tyrannical inclinations of a leader. It is key to that not only identify those who found a wish to manipulate control and treat in regulatory actions with subordinates, also offer them research to inculcate values of impartiality and principled behaviors in them.

In the previous era, place of work abnormality on work that come to be the attention of an collective numbers of exploration revisions (Colbert et al., 2004; Sackett & DeVore, 2001). Patterns of nonstandard performance embrace overpowering exertion, stealing, also drama roughly to colleaguesOrganizational permits refers to that an character's emotional affection to an organization. Preceding lessons have definite those entities who recognize with theirsproject based organizations up to some point might has a advanced level of job agreement (Vans Knippenberag & Van Schi, 2000; Vans Kanippenberg & Sleebos, 2006), that significant of work role and extra performance (Tyler & Blader, 2000), authentic colleague relations (Richter et al., 2006) also less level of revenue devotions (Abram et al., 1998).

At the theoretical level, leader behaviors should endorse and raise identification with the workgroup or organization, because such relational treatment transfers to individuals that they are valued and respected (Tyler, 1997). Definitely, because

despotic leaders exploit, illegally treat their followers and lack decent values and norms (Naseer et al., 2016), that we assume that a such leader may have low teamwork (Naseer et al., 2016) that in chance, less organizational identity. Mael & Ashforth, (1992) find that proof of identity is higher expected that rais in lack of hindrance with in that to the organization. Moreover, researchers (Tyler & Blader, 2000) argued that individuals classify higher with collective traditions. when expectation is contemporary of those the later matters theirs essential for emotional security. Tentative exploration gave provision for this idea. i.e many revisions, as well as cautious job, has show about that entrances of autocratic managers about that as less of honesty and reliability for others are adversely relation with organizational documentation (Bartels et al., 2006; Smidts et al., 2001). Depiction on that works, researcher have expectations a negative despotic leadership organizational credentials association.

Despotic and its significance usually roots base information about moral and good leadership is less as well as seen. only few research of present time has checked the plan relation among moral effectiveness. As well as we have also increase theoretical approaches to explore this relation. Generally we checked that manager upright leader action that higher relate to gain top management attention. We also lined manager ethical leadership to theirs subordinates about the running work of the organization also their personal interest wit in it. Positivism that insist in humanity conducting behaviour and positive feeling at work(Luthans, 2002) researcher give arguments positive leadership behavior will increase employees struggles, also organization motivate them for their desired toput teir efforts and obtain objective of organization but sine this can not be tested still.

In different of these component of rolling leader behaviors (Aronson 2001) argue that despotic manager which is created on single authority and rolling that willing for personal interest of manager he also imposed and manipulate of others. Despotic manager supremacy, rolling (Bass, 1990; House & Howell, 1992; Howell & Avolio, 1992; McClelland, 1975). In other terms a dishonest manager although he gain collective efforts through abusive administration and decrease self-respect

(Ashforth, 1994; Bass & Steidlmeier, 1999; Beu & Buckley, 2004; Bies, 2000; Howell, 1988; Tepper, 2000).

Workplace deviance has been broadly defined in two distinct categories including organization related deviance and person related or interpersonal deviance. The former is aimed against the organizational domain as a whole comprising of actions like purposely extending overtime, shrinking hours etc and interpersonal deviance is aimed against individuals that include actions like verbal abuse, sexual harassment etcetera (Mitchell and Ambrose, 2007). Workplace deviant behaviors may include behaviors like harassing other employees at work, suppression of information or efforts, theft, and behaving with rudeness towards fellow employees. The concept therefore has, both theoretical and practical significance for both researchers and organizations, as it has been identified as one of the key important element of overall job performance among the three components of job performance the other two are citizenship and task performance (Rotundo and Sackett, 2002), and is considered important because of its commonality at workplace with corresponding costs for organization (Bennett & Robinson, 2000).

Interpersonal deviant behaviors are fixed at fellow workers and include actions like making fun of someone, passing some ethnic, racial or religious remarks, playing a mean prank, passing hateful or painful remarks, behaving with rudeness or publicly embarrassing a colleague. Deviances at Organizational levels are targeted at the work domain in sum, consist of actions such as thieving, making longer than accepted work breaks, and coming late without permission, using an illegal drug or alcohol at work and withholding effort (Bennett & Robinson, 2000).

Earlier research has highlighted a number of factors as antecedents of workplace deviant behaviors by the employees. The review of literature on workplace deviance has shown three dimensional trends in research including deviance as reaction to negative experiences at work, personality features and social context (Bennett and Robinson, 2003). It has also been investigated that power and interdependence has influential effect on the victim's retaliatory behavior, and the dyadic relationship of the agent and target are central to understanding the response of the target (Herscovis et al 2012).

Robinson & Bennett (1995) they argued that workers deviance projected behavior due to lack of supervision they violate organization code of conduct they also harsh organization dignity, its member, (Bennett and Robinson 2000) agreed that facts of deviant workplace behavior involvements of deviant directly turn to individual also deviant behavior on work place linked to organization. That also the form of deviant behavior goes at individual of organization that can be abused rudeness and physical attack (Mulki, Jaramillo, & Locander, 2006; Robinson & Bennett, 1995). Unusual work behavior totally against the organization objectives that all such behaviors included as decreasing and harsh efforts (Colbert, Mount, Harter, Witt, & Barrick, 2004). Deviant work behavior reduced organization efforts that also pushed into millions loses yearly in United states (Harris & Ogbonna, 2006). That argue the deviant behavior on workplace in organization.

The workplace is that place in which different behaviors exist these are all have different aspects and nature have also different importance of organizational workers as well as organization performance. These behaviors also usually found in different models and norms of the organization. Organization also ruling of that group with predicted behavior, methods, norms and theories that give permission to perform work in easy mind set (Coccia, 1998). Although when that deviant goes to outside that unusually interrupt in organization norms and values that harsh all side of the workplace that also cause uncertainty in a workers union and decision making process of the organization also efficiency and economic costs (Coccia, 1998).

The management of rude behavior in the workplace that cause anxiety with in organization and its workers on outside these behaviors are creating losses in economically as well as financially wellbeing. However the negative deviant behaviors knocked out, whether it includes sensual incitement, demolition, report dispersion, and profit-making disturb or if not, illegal organizational behavior has adverse consequences for the object. Adverse unusual behaviors include employee failures such as not subsequent the manager's commands purposely reducing decrease the work rotation, external late, forcing minor stealing as well as not debating co-workers with respect or acting crudely with colleague (Galperin, 2002). That is vital to note that variance among immoral behavior and adverse unusual behavior since while



the previous contracts with the breach of social rules that later centers on damage of important organizational norms (Spreitzer and Sonenshein, 2004). Optimistic different actions that some action may not give permission by the organization but appreciate the organization to gain its main objectives that behavior may improve quality of work positive behavior may include advanced level of thinking and decision of organization with different management, commands also sort out competent leader (Galperin, 2002).

Negative behavior during job performance that has been noted that is unsettling behavior (Robinson & O'Leary-Kelly, 1998), that also misconducting Vardi & Wiener, 1966), unethical behaviors (Puffer, 1987), workers job variation and deviant Robinson & Greenberg, 1998) that also misused of working environment (Griffin et al., 1998), this research just focused on sources of deviant work place behaviors as defined by (Robinson and Bennett 1995). Many researchers focused on deviant workplace behavior Deviant workplace behavior has been the point of a few examinations and this idea may seemingly be viewed as the most completely settled (Bennett and Robinson, 2000; Robinson and Bennett, 1995; Robinson and Greenberg, 1998) i.e., researchers have observationally built up an exhaustive typology of deviant workplace behaviors and approved potential strategies for estimating workplace aberrance.

Workplace deviance has been distinctive as professional conduct that delays significant organizational standards and in this manner compromises the prosperity of an association, its individuals, or both (Robinson and Bennett, 1995). This measurement connoted the target of the deviant behavior. The measurement ranged from deviant behavior expected at the organization (sabotaging hardware) to deviant conduct for the most part engaged at an individual from the organization (inappropriate behavior). The subsequent measurement showed the seriousness of the deviant behaviors. Deviant behavior on this component distinctive on an assortment from minor types of deviance (tattling about individual workers) to genuine types of deviant behavior (physical maltreatment).

Over the earlier decade, there has been a development in dedication to counter-productive working environment behaviors together with viciousness, burglary,

deceptive nature, volitional truancy, medication and liquor misuse, and antagonistic vibe, a large number of which have been tended to in this exceptional issue. Strengthening the attention regarding these particular kinds of behaviors has been an explosion of speculations created to clarify, comprehend, and oversee counterproductive behavior. While these theories have talked numerous clearly dissimilar kinds of behaviors, numerous correspondences exist between and among these different perspectives. In this article, we take part these different recognitions into a cognitive context, offering that people's affirmations about the causal extents of workplace occasions are an essential factor rousing both the responses and behaviors that outcome in counterproductive workplace behaviors.

In pondering meanings of counterproductive work behaviors, (Collins and Griffin 1998) note that practically the majority of the definitions state that counterproductive workplace behaviors are portrayed by a disregard for general and hierarchical principles and guidelines. Furthermore, they note that counterproductive behaviors can mixture in seriousness from low (for example insignificant taking) to high. Essentially, (Hogan and Hogan 1989) see counterproductive occupation conduct as a build covering every deviant behavior running from absence to attack. Different definitions show that counterproductive workplace behaviors are activities that undermine the prosperity of an association and its individuals, and disrupt verifiable and categorical guidelines about common, deferential, and fitting conduct (for example Nobleman and Richardson 1994; Martinko and Zellars 1998; Robinson and Bennet 1995). We concur with these perspectives and view counterproductive conduct as conduct by a hierarchical part that outcomes in hurting the association or its individuals.

Workplace deviance has been broadly defined in two distinct categories including organization related deviance and person related or interpersonal deviance. The former is aimed against the organizational domain as a whole comprising of actions like purposely extending overtime, shrinking hours etc and interpersonal deviance is aimed against individuals that include actions like verbal abuse, sexual harassment etcetera (Mitchell and Ambrose, 2007). Workplace deviant behaviors

may include behaviors like harassing other employees at work, suppression of information or efforts, theft, and behaving with rudeness towards fellow employees. The concept therefore has, both theoretical and practical significance for both researchers and organizations, as it has been identified as one of the key important element of overall job performance among the three components of job performance, the other two are citizenship and task performance (Rotundo and Sackett, 2002), and is considered important because of its commonality at workplace with corresponding costs for organization (Bennett & Robinson, 2000).

Interpersonal deviant behaviors are fixed at fellow workers and include actions like making fun of someone, passing some ethnic, racial or religious remarks, playing a mean prank, passing hateful or painful remarks, behaving with rudeness or publicly embarrassing a colleague. Deviances at Organizational levels are targeted at the work domain in sum, consist of actions such as thieving, making longer than accepted work breaks, and coming late without permission, using an illegal drug or alcohol at work and withholding effort (Bennett & Robinson, 2000).

Extending research under these domains, list of behaviors have been identified that include behaviors aimed at organizations like theft, stealing, resentment, absenteeism, sadism, late arrival, and put forth less efforts into work. Likewise at interpersonal level, workplace deviant behaviors include the act of teasing others, deceitful tactics, and performing selfishly. These concepts have gain much attention over a period of recent times (Kidwell & Martin, 2004) and such behaviors constitute a remarkable cost for the organizations (Bennett & Robinson, 2003).

Earlier research has highlighted a number of factors as antecedents of workplace deviant behaviors by the employees. The review of literature on workplace deviance has shown three dimensional trends in research including deviance as reaction to negative experiences at work, personality features and social context (Bennett and Robinson, 2003). It has also been investigated that power and interdependence has influential effect on the victim's retaliatory behavior, and the dyadic relationship of the agent and target are central to understanding the response of the target (Herscovis et al 2012). Abusive supervision (a form of workplace bullying) has been reflected as prospective originator of counterproductive work behaviors

(Tepper et al. 2009). Further employee's deviance has been shown as hot effective response to negative forces at workplace. Based on the arguments mentioned above it can be argued that workplace bullying may lead to workplace deviant behaviors and therefore it is hypothesized that.

In spite of the fact that we recognize and portray a two-arrange process where people (1) see some sort of disequilibrium (for example foul play or imbalance) in the workplace; and after that (2) make an attribution for the disequilibrium; we have chosen to concentrate fundamentally on the distributional side of this procedure. There are two explanations behind this. In the first place, it gives the idea that there is a moderately high level of agreement in regards to the procedure by which results are assessed. In spite of the fact that the ongoing writing has called attention to that there are a wide range of methods for portraying the idea of the assessment procedure including relative instead of total value (Martinko 2000) and distributive, procedural, and universal equity (for example Folger and Skarlicki 1998; Murray 1999). According to this literature background we hypothesis the following relationship:

**H<sub>1</sub>: Despotic leadership positively related with deviant work place behavior**

## **2.2 Mediating Role of Negative Affectivity between Despotic Leadership and Workplace Deviant Behaviors**

Despotic leaders are tyrannical, controlling, and limit commitment in official (Aronson, 2001; De Hoogh and Den Hartog, 2008), and they accomplishment and illegally treat their followers. Representatives inside this contention relationship may think that its tricky to channel their reactions straightforwardly toward the criminal specialist figure (i.e., despotic leaders), yet may do as such through deviant effects, for example, by dropping desired behavior. Given that leaders authorizing is a control of his/her supporters' exercises, and that leaders are delegates of

an association, representatives are conceivable to react in manners that damage together the leader and organization.

Dispositional factors comprise of constant and regular ways of thinking, feeling, or acting shown by individuals, and these factors are shown act as a “Frame” for evaluating the situations (Judge et al. 1997). Among the traits list two affective states, which are Negative and Positive affectivity have been highlighted by the researcher which are conceptually and empirically distinct from each other’s and have stability over time (Watson, et al., 1988). Negative affectivity is explained as the personal propensity to sense different of negative affective states, generally characterized by sentiments that include nervousness, dread, sorrow, and annoyance (Watson & Clark, 1984).

High negative affectivity individuals practice high levels of general distress, depression, anxiety, and anxiety and are predisposed to to feelings of anger, dislike, disgust, and fear (Watson et al., 1988). A person who is characterized scared, anxious and sad is considered to be more prone victims to possible perpetrators(Samnani and Singh, 2012). Positive affectivity on the other hand provide enthusiasm, activeness and alertness, and empirically in relevance to the attributes of extravert personality trait (Watson et al., 1988).

Negative affectivity is generally associated with neuroticism (George, 1992) and it has been argued that experience of undesirable events can add significantly to negative affectivity (George, 1995). The consistent negative behaviors of perpetrator tends to produce negative affect in victims and more susceptible individuals respond with enhanced negative emotional states, and are thus more vulnerable physical sickness (Watson, 2000) and the victims generally are found with enhanced intensities of negative effect (Coyne et al., 2000; Glaso et al., 2007). Negative affectivity was found highly correlated with bullying exposure and it has been argued that experience of bullying and negative affectivity state intermingle in a spiteful loop of occurrences, hence interpersonal mistreatment may provoke high level of discomfort in victims; and resultantly they will behave aggressively towards others with negative attitudes (Mikkelsen and Einarsen, 2002).

Brought down representative introduction may likewise result as of the despotic leader debilitated inspirational effect on the worker. Leaders who are valid and dependable are bound to improve supporter encouragement, trust, reliability, and hierarchical nationality practices (De Hoogh and Den Hartog, 2008). By uniqueness, when a pioneer's moral character is dangerous, s/he will be not able impact representatives to accomplish individual or potentially authoritative expectations (Kanungo, 2001). As despotic leaders nonappearance unwavering quality and benchmarks, adherents under these leaders are probably going to interrogate standards concerning powerful exhibitions, which results in lower work execution, nationality practices toward both the association and others, and arranged innovativeness.

The wonder of leadership joins a person's capacity to impact others devotees to help accomplish authoritative goals. Since its origin, the area of leadership has been romanticized, accentuating the positive impacts of leaders on supporters and associations (Schaubroeck et al., 2007). Rising enthusiasm for the useless parts of leadership proposes a noteworthy change in perspective (Karakitapoglu-Aygun and Gumusluoglu, 2013) that distinguishes the negative impacts that leaders can apply over their subordinates. The term negative affectivity was utilized by (Tellegen 1982) and characterized by (Watson and Clark 1984) as a temperament dispositional measurement that reflects common individual contrasts in negative emotionality and self-idea. Based on a complete survey of the writing in regards to NA, Watson and Clark decided, in addition to other things that high-NA people slope to concentrate differentially on the adverse qualities of themselves, other individuals, and the world when all is said in done (i.e., they emphasize the pessimistic) and that high-NA people are have various characteristics.

Negative affectivity is a character variable estimating particular corrections in negative emotionality and self-idea, was assessed consuming Nemours things taken, with minor changes, from the Minnesota Multiphasic Personality Author. These 50 items make up the Taylor Apparent Anxiety Scale (TMAS, Taylor, 1953). The TMAS is a genuine false scale that incorporates such things as "I don't tire quickly" and "I can't keep my psyche on a certain something". It is scored by including

the occasions a respondent addressed consistent with specific questions and false to Other questions. It is, along these lines, a thing tally of the quantity of NA explanations that apply to a respondent. The scale has demonstrated no critical contrasts among people, and test-retest reliabilities have been more noteworthy than .80 for periods going from 3 weeks to 17 months (Taylor, 1953). As of late, Watson and Clark (1984) announced that the normal inward consistency gauge for the TMAS is .82, and that it associates very (i.e.,  $r$  a .70) with 12 other character measures. Indeed, they noticed that the TMAS just as the other personality measures, which clearly check different character qualities, for example, uneasiness, neuroticism, sense of self quality, general maladjustment, etc, really measure a similar stable attribute of NA.

The organization past their quick undertaking presentation. Meta-logical discoveries have recognized a positive connection between worker and hierarchical execution (Podsakoff, Whiting, Podsakoff, and Blume, 2009), which supports significant job in progressing authoritative working. At last, representative innovativeness has been connected to a progressively inventive organization (Amabile, 1988), just as to more prominent authoritative execution (Nystrom, 1990). Thus, recognizing a negative effect of despotic leadership on these significant results would comprise a influence case for its negative impact on the general capability of the organization.

Past research analyzing the negative connection between despotic leadership and supporters' positive thinking and impression of a leader capability indicates conflicting detections (De Hoogh and Den Hartog, 2008). The creators contended that the degree to which despotic leadership contrarily impacts devotee results may rely upon situational factors that could reinforce the relationship (De Hoogh and Den Hartog, 2008). One such factor is a seen authoritative legislative issue which describes a worker's close to home evaluation of how much the hierarchical condition is political (Ferris, Harrell-Cook, and Dulebohn, 2000; Harrell-Cook, Ferris, and Dulebohn, 1999) Negative effect.

General proof determines that two wide state of mind factors Positive Affect and Negative Affect are simply the overpowering measurements declared mind set (Watson, Clark, & Tellegen, 1984; Watson and Tellegen, 1985). In spite of the

fact that their names may recommend that they are inverse posts of a similar measurement, Positive and Negative Affect are in truth very unmistakable measurements that can be expressively spoken to as equal (uncorrelated) factors. Both temperament elements can be estimated either as a state (transient fluctuations in mind-set) or as a quality (stable individual contrasts all in all emotional tone). Our article will accentuation on the characteristics, which (Tellegen, 1982) has named Negative Affectivity and Positive Affectivity.

Counterproductive work environment conduct has turned into an undeniably famous point of concentrate among authoritative specialists. CWB alludes to conduct by representatives that damages an association or its individuals (Spector and Fox, 2002) what's more, incorporates acts, for example, robbery, harm, verbal maltreatment, retaining of exertion, lying, declining to coordinate, and physical attack. Throughout the years, different analysts have examined a comparable arrangement of practices, however they have utilized diverse phrasing relying upon their hypothetical center, including: hierarchical wrongdoing (Hogan and Hogan, 1989), organization stimulated hostility (O'Leary-Kelly, Griffin, and Glew, 1996), authoritative retaliatory practices (Skarlicki and Folger, 1997), work environment hostility (Baron and Neuman, 1996), working environment deviance, (Bennett and Robinson, 2000; Robinson and Bennett, 1995), vengeance (Bies and Tripp, 1998), and withdrawn conduct in associations (Giacalone and Greenberg, 1997). Until this point in time, most of research here has concentrated on recognizing ecological predecessors of CWB, for example, work stressors, and distinguishing character characteristics, for example, negative affectivity, that may expand a person's inclination to take part in CWB. Be that as it may, while scientists concur on a between actionist point of view in regards to the commitments of both individual and condition factors in anticipating conduct, few have explored both with CWB in a similar report (Aquino, Lewis, and Bradfield, 1999; Skarlicki, Folger, and Tesluk, 1999). In addition, various investigations around there have analyzed the connections between potential stressors and CWB utilizing a solitary wellspring of information, for the most part self-report. The reason for the present investigation



is two fold (1) to evaluate the impacts of a new position stressor, work environment incivility, on worker fulfillment, and CWB; and (2) to reproduce discoveries from past research with respect to the connections between employment stressors, negative affectivity, and CWB utilizing peer-revealed information.

Rationally, work environment rudeness covers a lot with interactional equity. Interactional equity was initially conceptualized as a sub-measurement of procedural equity characterized as the nature of relational treatment got during the order of authoritative techniques (Bies and Moag, 1986). Two of the five criteria for decency in between close to home treatment recognized by (Bies and Moag 1986) cover with work environment incivility: (a) regard (e.g., civility, dodging purposeful discourteous or assaulting practices); and (b) legitimacy of inquiries (e.g., staying away from ill-advised inquiries). Be that as it may, as Cortina, Magley, Williams, and Langhout (2001) point out, interactional equity centers fundamentally around treatment got from a boss or others in power as formal authoritative strategies and methods are actualized, though working environment incivility is more extensive and incorporates treatment from any individual from an association and isn't restricted to formal procedural settings.

Experience is altogether different. Andersson and Pearson (1999) recognized the social idea of working environment incivility and contended that demonstrations of incivility can possibly cultivate disagreeable trades or even lead to increasingly genuine behaviors. They depict an rudeness winding wherein a demonstration of work environment incivility with respect to one individual prompts a demonstration of incivility by a second gathering that might be of equivalent or expanding power. In the previous case, the trade is non-raising. The last case, then again, brings about a heightening winding wherein each demonstration is trailed by an undeniably negative act. CWB, maybe coming about at last in hostility or viciousness wherein the aim to cause mischief is undeniable.

Negative affectivity indicates to the dispositional inclination to encounter an assortment of negative mind-set states (Watson and Clark, 1984). People high in

pessimistic affectivity have been portrayed as particularly delicate to minor dissatisfactions and disturbances, and are bound to experience contrary feelings, for example, tension, blame, outrage, dismissal, bitterness, and trouble. Researchers have proposed that the reason high-negative affectivity people experience progressively antagonistic feelings is that they see the world more contrarily than low-contrary affectivity people (Chen and Spector, 1991; Jex and Beehr, 1991). At the point when stood up to with distressing conditions, including incivility wherein the aim to damage is available to translation, high-negative affectivity people may credit increasingly vindictive thought processes to the entertainer prompting expanded contrary passionate excitement, which may prompt CWB. People low in negative affectivity, then again, may give the on-screen character the advantage of uncertainty and ascribe the conduct to progressively benevolent causes, empowering them to continue without wanting to react.

Past research has demonstrated that people react diversely to stressors as a component of jobs that are resolved to a limited extent by one's sexual orientation (Ivancevich and Matteson, 1980). In spite of the fact that there are not many word related pressure thinks about that have analyzed sexual orientation contrasts, it has reliably been demonstrated that females report more negative feelings and mental strains than men (Beena and Poduval, 1992; Jick and Mitz, 1985). Be that as it may, with respect to physical strains, contrasted with men, ladies will in general show lower paces of mortality from coronary illness (CHD), cirrhosis of the liver, and suicide, which are all viewed as pressure related results (Costa and McCrae 1987). In general, these distinctions propose that ladies are almost certain than men to experience and report numerous types of negative emotionality because of stressors.

The current research on NA proposes that it has a mind boggling job in the activity stress process past its conceivable biasing effect on appraisal. It has been appeared to correspond significantly with numerous proportions of employment stressors and occupation strains, yet the purposes behind these relations should be clarified. We will proceed with our dialog by diagramming existing endings concerning the predisposition instrument. Following that will be a dialog of six

substantive systems which appear to be achievable, and the proof in help of each. They are not planned to be totally unrelated and it is conceivable that they all assume a job. The instruments are: observation, hyper-responsively, determination, stressor creation, disposition, and causality components. We will at that point come back to the issue of why martialling can prompt mistaken outcomes.

Research has assembled up individual differences in the propensity to experience negative feelings. The most every now and again concentrated of these demeanors is attribute uneasiness, despite the fact that outrage and despondency have additionally been given consideration. Watson and associates (e.g., Watson and Clark, 1984; Watson and Pennebaker, 1989), taking note of that different proportions of affective issue were emphatically inter-correlated, built up the negative affectivity develop, setting that specific people were inclined to experience pain and pessimistic feelings. In this way NA is a more extensive build than quality tension or other affective demeanors. In the hierarchical space specialists have would in general receive the NA idea when contemplating affective airs, in spite of the fact that proportions of individual unavoidable feelings (e.g., attribute tension) are regularly utilized reciprocally with more extensive estimates that evaluate an assortment of negative feelings.

Negative affectivity (NA), a character variable estimating singular contrasts in adverse emotionality and self-idea, was estimated utilizing 50 things taken, with slight alterations, from the Minnesota Multiphasic Personality Inventory. These 50 things make up the Taylor Manifest Anxiety Scale (TMAS, Taylor, 1953). The TMAS is a genuine false scale that incorporates such things as "I don't tire rapidly" and "I can't keep my psyche on a certain something." It is scored by including the occasions a respondent addressed consistent with specific inquiries and false to different inquiries. It is, along these lines, a thing check of the quantity of NA articulations that apply to a respondent. The scale has demonstrated no noteworthy contrasts among people, and test-retest reliabilities have been more noteworthy than .80 for periods going from 3 weeks to 17 months (Taylor, 1953). As of late, Watson and Clark (1984) detailed that the normal inner consistency gauge for the TMAS is .82, and that it associates exceedingly (i.e.,  $r = .70$ ) with 12

other character measures. Truth be told, they noticed that the TMAS just as the other personality measures, which clearly check various character characteristics, for example, tension, neuroticism, inner self quality, general maladjustment, etc, really measure a similar stable attribute of NA. Thus we hypothesis that

**H<sub>2</sub>: Negative affectivity mediates the relationship between despotic leadership and deviant workplace behavior.**

## 2.3 Moderating Role of Trait Anxiety

Various neurocognitive reproductions of Anxiety underline the significance of a hyper-responsive risk identification structure concentrated on the amygdala, with current records including a job for prefrontal devices in controlling politeness to peril. Here we explored whether characteristic tension is connected with a much far reaching deregulation of civility control. Offers played out a reaction strife task under circumstances that presented high or low weights on dedication. High trait-on control people indicated diminished prefrontal activity and more slow objective distinguishing proof in response to treating battle when the undertaking did not totally involve consideration riches. The relationship among trait anxiety and prefrontal staffing stayed after administrative for state anxiety. The main focus of the study to describe affect and causing of trait anxiety in cross culture research (Spielberger, et al., 1970).

These ends demonstrate that trait anxiety is identified with poor enlistment of prefrontal consideration control apparatuses to repress distractor treating notwithstanding when risk related boosts are far away. Particularly, this shortage was seen when continuous errand related requests on consideration were low, conceivably disclosing the everyday confusions in mindfulness that are connected with clinical anxiety.

The Spiel Berger State-Trait Anxiety is one of the most generally utilized proportions of anxiety in down to earth outlook look into. It is a dependable and unobtrusive proportion of anxiety. Its ubiquity has implied that analysts can contrast their outcomes and those of others, a helpful however uncommon event in

such research. The one issue, be that as it may, with the STAI is its length, being 40 things in length. This is a deterrent to its utilization in concentrates anyplace time for finishing surveys is constrained. It is likewise an obstacle for certain occupants who can't or ill-equipped to finish broad scales with clearly dull things. These issues could be to a great extent overwhelmed by the development of an institutionalized short-type of the STAI. The Spiel Berger State-Trait Anxiety Inventory comprises of two surveys of 20 things each.

Scholarly investigations from the 1980s and 1990s suggest that anxiety is classified by expanded consideration catch by danger related stimuli 2, 3. The prevalent hypothetical position has been this emerges because of a hyper-responsive pre-mindful risk location framework fixated on the amygdala. This record has been changed as of late to consolidate an impact of prefrontal cortical components in the top-down control of particular consideration regarding threat<sup>5,6</sup>. Be that as it may, these models have held a featuring on the requirement for rivalry between the treatment of risk related and unbiased improvements to be available for anxiety-related psychological biases to be watched in the event that trait anxiety is connected with broke dynamic staffing of prefrontal control apparatuses to oversee the arrangement of consideration when it isn't completely constrained by the main job, at that point we would figure this would be seen under such conditions: that is, as a reason for response struggle under conditions of low, however not high, perceptual burden. Despite the fact that trait anxiety has been affirmed to be adversely connected with the prefrontal reaction to risk related distractors under comparable conditions<sup>8</sup>, it isn't potential to build up whether inconvenience to cortical consideration components is optional to expanded subcortical responsively to danger related improvements or the other way around with the thoughtfulness regarding danger technique that was utilized a method that controls the need to apply deliberate control in response to changes in treating rivalry in the lack of danger related impetuses is required to stay away from this issue.

The information expressed here suggest that trait anxiety is connected with lacking enlistment instruments that are utilized to expand purposeful control because of handling struggle. Especially, this was just seen under conditions where the

division of attentional assets isn't completely administered by the essential undertaking and where upkeep of errand situated passing out may require preliminary by-preliminary intonation of consideration control as an element of reaction struggle. This ruined enlistment of prefrontal attentional control systems was watched utilizing an absolutely discerning undertaking without danger related motivating forces. It ought to likewise be noticed that this insufficient staffing was basically related with trait and not national anxiety, proposing that it mirrors a treating style or deficiency that is related with presentation to anxiety instead of a symptomatic result of modified mind-set state. So, we hypothesis that

**H<sub>3</sub>: Trait anxiety moderate the relationship between despotic leadership and negative affectivity in such a way the relationship will be stronger with high trait anxiety than lower.**

## 2.4 Theoretical Framework

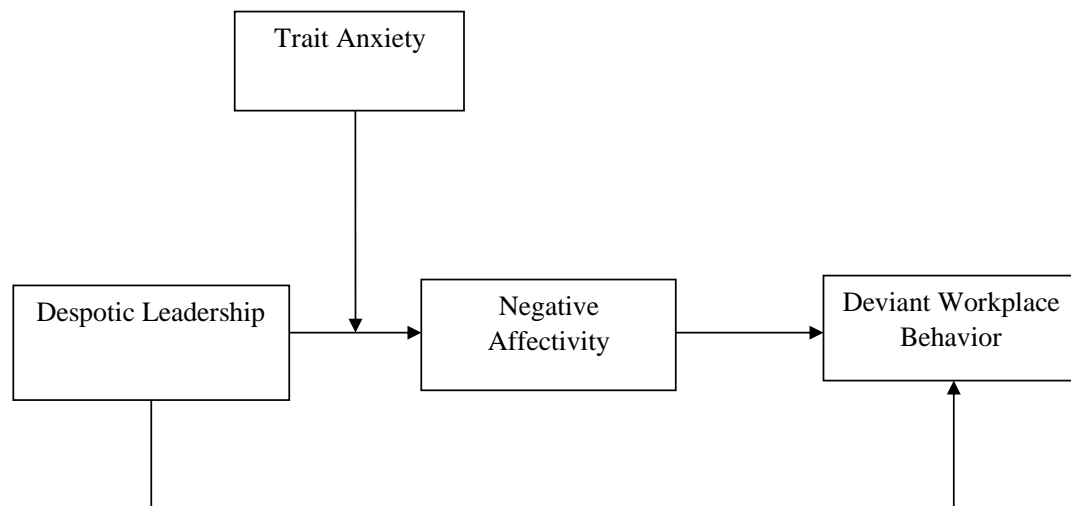

# Chapter 3

## Research Methodology

### 3.1 Research Design

The management of research question is based on research design that provides guideline, plan and course of action to process the proposed investigation. The objectives of this study are to find relationship among the framed variables in the study in the domain of project based organizations of Pakistan within the capital city of Islamabad. The standard components of research design include type of the study, study setting, time horizon or limit with respect to data collection, unit of analysis for survey, data collection and procedure and sampling units etc., which will be highlighted in details in this section.

#### 3.1.1 Study Type

The current study examined the impact of Despotic leadership on workplace deviant behavior.

In this study, we have used negative affectivity as mediator and trait anxiety has been used as moderator. Basically this is a co-relational study as it tested the variables in same year on different respondents in private sector organization. This study was conducted as part of the academic requirement and because of time constraints, convenience sampling technique was used. Due to power distance and

bureaucratic style of hierarchy, the cultural aspects of Pakistani working environment in organizations specifically entail considerable levels of despotic experiences and similar negative concepts. Therefore based on earlier research findings and directions, the private sector organizations have been selected for this study.

### **3.1.2 Study Setting**

For response measurement through questionnaire, respondent were contacted on their working places. Therefore this is a field study. Respondent were ascertained about the confidentiality of their responses which enabled them to provide their response with honesty and comfort.

### **3.1.3 Time Horizon**

For the purpose of this study the data were collected from private sector project based organization in the capital city of Islamabad and Rawalpindi. The study is cross sectional, as it took almost four months to collect data from the respondents in two times lags from January 2019 to April 2019.

### **3.1.4 Research Interference**

No research related interruption has been observed to affect findings in this study.

### **3.1.5 Unit of Analysis**

The unit of analysis is the individuals e.g. employees working in project based organizations in Islamabad and Rawalpindi were the respondents of the current study.

### **3.1.6 Data Collection Process**

Despite the fact that a large number of research has been conducted having influential findings and different exposure are conducted in the country, still data



collection is highly problematic because respondent don't know how to response, how to fill the questionnaire as well. However, during data collection we have explained the measurement and purpose of study in front of respondent then they filled data. Generally, respondents feel reluctant to convey their opinion even though, as conveyed to them and ensured that the study is for research purpose.

In such scenario, conduct of quality research is a challenging task for the researchers and particularly students who lack the relevant resources to conduct survey or data collection. Therefore, data collection process from the employees of project based organizations involves considerable efforts and time.

## **3.2 Population and Sampling**

### **3.2.1 Population**

For the study we have population of interest consisting of employees working in different project based organizations in capital city of Islamabad.

### **3.2.2 Sample and Procedures**

Because of time limitations convenience sampling has been used in this study. Respondents were reached using researcher's professional and personal contacts & references. The exclusion criterion for respondents included (a) employment with the respective organization for less than 6 months (ensuring that the supervisor had done performance appraisal of the subordinate at least once); (b) have qualification less than matric (to ensure that they could easily understand and fill a questionnaire). Participation was voluntary and confidential.

## **3.3 Scales**

Following referenced questionnaires have been used for data collection;

- Despotic Leadership (Hanges & Dickson, 2004)
- Workplace Deviant Behavior (Bennett and Robinson, 2000)
- Negative Affectivity (Watson, et al., 1988)
- Trait Anxiety (Lehrer, Paul, Robert & Woolfolk, 1982)

### 3.3.1 Despotic Leadership

The six items scale is used for measurement which is developed by (Hanges & Dickson, 2004). From the study of “the development and validation of the GLOBE culture and leadership scales”, which is also used by (Hoogh & Hartog, 2008), and will filled by Pakistani industries employees and their supervisor on five dimension Likert scale where 1 = strongly disagree, 2 = disagree, 3 = neutral, 4 = Agree and 5 = Strongly Agree. Cronbac’s alpha value of the despotic leader is 0.823.

### 3.3.2 Negative Affectivity

Negative Affectivity (State) has been assessed with scale comprising of 10 items derived from “Positive and Negative Affect Schedule (PANAS)”, scale, initially established by Watson, et al (1988). The respondents of the study were questioned to specify and mark, as to what degree they had sensed a specific feeling or emotion within the span of previous two weeks. The states list include emotions like upset, scared, hostile, ashamed, irritable etc. The responses were noted on 5 point scale from 1 to 5 (for very slightly, a little, moderately, quite a bit, and extremely respectively).

### 3.3.3 Workplace Deviant Behaviors

Workplace deviant behaviors have been measured with a set of 12 items, derived from scale developed by Bennett and Robinson (2000). The scale consist of a 5 point scale (where 1 for never and 5 for daily in degree). The respondents of the study were questioned to specify the number of times they have engaged in the

given behavior within the previous one year. The response is however particular to the organization, they are currently employed in.

### **3.3.4 Trait Anxiety**

The four items scale is used which is developed by (Lehrer, Paul, Robert & Woolfolk, 1982) from the study of “Self-Report Assessment of Anxiety”. And will filled by the employee of the Pakistani industries on five dimension Likert scale where 1 = strongly disagree, 2 = disagree, 3 = neutral, 4 = Agree and 5 = Strongly Agree. Cronbach’s alpha value of trait anxiety is equal to 0.539.

## **3.4 Measures**

Data from the respondents has been collected through adopted questionnaires as compiled from different sources of referenced variables. Employees filled questionnaires while rating their respective opinions according to the nature of the questionnaire items, relating to despotic leadership, negative affectivity, workplace deviant behaviors and trait anxiety. Responses on workplace bullying and workplace deviant behaviors have been obtained with a five- point scale (1 for strongly disagree and 5 for strongly agree). Negative affectivity has also been marked with a five -point scale (1 for very slightly or not at all and 5 for extremely). Response on trait anxiety has also been obtained on a five-point scale (1 for strongly disagree and 5 for strongly agree). As a standard, the questionnaires also have four demographic factors to obtain information about the respondents’ gender, age, qualification and experience. However, none of the demographic variables revealed significant differences in any of the three dependent variables, so did not control these in further analysis.

### 3.5 Reliability

The data collected have been tested to check for its reliability. The reliability results along with number of items are depicted in front of each variable in the following table:-

TABLE 3.1: Scale Reliabilities.

Variable	Cronbach's Alpha	No. of Items
Despotic Leadership	0.875	6
Negative affectivity	0.710	10
Workplace Deviant Behaviors	0.858	12
Trait Anxiety	0.62	4

For an instrument or scale it's imperative to be reliable. Reliability of a scale is consistency of the results when run through different situations. Internal consistency or homogeneity is the degree to which all of the items of a scale measure the same construct. The most common check for assessing the internal consistency of a scale or instrument is Cronach's  $\alpha$ . The value of Cronach's  $\alpha$  fall between 0 and 1, however in case of higher  $\alpha$  value by an instrument, it is generally considered to have higher reliability and for lower  $\alpha$  values the reverse is applicable. In case of this study, the scores of Cronach's  $\alpha$  for the entire variable are shown in Table 3.1, and as shown all variables have acceptable level of reliability in terms of Cronach's  $\alpha$ . The scale for workplace deviant behaviors has the highest Cronach's  $\alpha$  value (0.858) and therefore has high internal consistency. Despotic leadership as the highest  $\alpha$  value (0.87) among the given variables and it is within acceptable range.

### 3.6 Sample Characteristics

Out of 167 respondents male respondents were 132 with 79.0% and female were 35 with 21.0%. While age of respondents was divided into different categories like: age between 20-30 were 54 with 32.3%, 31-40 were 80 with 47.9%, 41-50 were 13

with 7.8% and last but not the least 51 and above respondents were 20 with 12.0%. Now looking to the qualifications of these respondents. Participants have different educational backgrounds like: 30 respondents (18.0%) have a Bachelor degree, 106 respondents (63.5%) have a Master degree, and 31 respondents (18.6%) have a MS degree. While working in different they (the respondents) have some job experience (in years), which is categorized in 5-10, 11-15, 16-20, 21-25 and 25 years or above. Respondents have 5-10 years of experience were 80 with 47.9%, 11-15 years of experience were 50 with 29.9%, 16-20 years of experience were 13 with 7.8%, 21-25 years of experience was 1with 0.6%, 26 and above years of experience were 23 with 13.8%. All the tabulated data of all the above mentioned details are given in Table 3.2.

TABLE 3.2: Respondents' demographic characteristics.

	Frequency	Percent	Cumulative Percent
<b>Gender</b>			
Male	146	80.0	80.0
Female	36	19.0	100.0
<b>Age (Years)</b>			
20-30	62	34.3	34.1
31-40	86	47.9	81.3
41-50	13	7.8	88.5
51 and above	21	11.0	100.0
<b>Qualification</b>			
Bachelor	31	17.0	17.0
Master	116	63.5	80.8
MS	35	19.6	100.0
<b>Experience (Years)</b>			
5-10	86	47.3	47.3
11-15	56	30.8	78.0
16-20	14	7.7	85.7
21-25	1	.5	86.3
26 and above	25	13.7	100.0

# Chapter 4

## Data Analysis and Results

### 4.1 Descriptive Statistics

Descriptive statistics summarized the details of all observations drawn from the data with the use of various statistical tools. Descriptive statistics not only provide the basic information about the data set, but can be shown to highlight the possible relationship or relativeness of the variables used in data. It summarized a large data in such a way that can be made available for interpretation on the basis of different statistical attributes (Like range, average, deviations). Generally, it shows the information or scores related to data in the form of the sample size, minimum and maximum values and standard deviation etc. The details of the present study from the collected data in summarized form are shown in Table 4.1.

TABLE 4.1: Descriptive Statistics (Minimum, Maximum, Mean and Standard Deviation).

Variable	Sample	Min	Max	Mean	Std. Dev.
Gender	182	1	2	1.21	.408
Age	182	1	4	1.99	.941
Qualification	182	2	4	3.01	.606
Experience	182	1	5	2.02	1.353
Despotic Leadership	182	1	3.33	3.3629	.51181
Negative affectivity	182	1	4.60	3.9297	.62565

---

Workplace Deviant Behaviors	182	1	4.42	3.9917	.78853
Trait Anxiety	182	2	5.63	3.9499	.50749

---

The above table express all the summarized descriptive statistics of all variables used in the current study including, qualification, age, experience.

The summarized form of For each variables, the minimum, maximum and average values of all variable are mentioned with respective mean and standard deviation. The first column in the table gives information about the variables that has been used in the study.

The second column shows the sample size which is number of respondents. Minimum and maximum values are presented in the third and fourth column of the table, while mean vales and values of standard deviation for the data are depicted respectively in fifth and sixth column of the table. In case of gender, the measure has been presented on two factors categorization, therefore male is indicated by 1 and female is depicted by 2, hence the maximum value in this case is 2. For despotice leadrship mean value is 2.1627 with standard deviation of 0.51181. Negative affectivity reported mean value of 2.7964 with standard deviation of .62565. Workplace Deviant Behaviorshas a mean value of 2.7774 and indicates standard deviation of .78853. For trait anxiety of Control the corresponding mean value is 3.9499with standard deviation of .50749.

## 4.2 Control Variables

Literature shows that demographic variables gender, age, qualification and experience have significant effect on individual attitude and behavior. But in this study we saw in the result of ANOVA from Table 4.2 that none of the demographic variable is significant to the outcome variable employee performance. So in our study there is no need to control the demographic variables.

TABLE 4.2: Control variables (ONE WAY ANOVA).

Control Variables	Mean Square	F	Sig.
Gender	0.547	.725	.06
Age	0.543	.227	.622
Qualification	0.546	.303	.413
Experience	0.542	.902	.402

*Sig. level  $p < 0.05$*

### 4.3 Confirmatory Factor Analysis

All the variables in the study i.e. despotic leadership, negative affectivity, and deviant workplace behavior and trait anxiety were answered by the employees from the project based organization. The employees are red cross from different sectors of Pakistan, so it is necessary to test whether employees perceives this construct different from one another and will also check that our model is fit for the purpose or not. For that purpose confirmatory factor analysis has been conducted to check the validity of the study variable. To check the validity of variable and fitness of model to the purpose we use software AMOS (21 versions).

TABLE 4.3: CFA Results (Four factor solution).

Model Fit Factors	CMIN/DF	RMSEA	IFI	TLI	CFI
Initial Values	5.40	.14	.66	.65	.70
Final Values	3.00	.05	.90	.89	.90

Table 4.3 indicates the initial values of the model in the first row, which is not acceptable in threshold estimates. But it can be improved by joining the higher value of error terms. After joining the higher values from error terms the value of chi-square/df (CMIN/df) become acceptable in the threshold estimate (CMIN/df = 3.00). RMSEA (root mean square error of approximation) was first unacceptable in threshold value, because RMSEA value was greater than 0.1, which is bad value, but after joining the value of higher value of error term the value of RMSEA



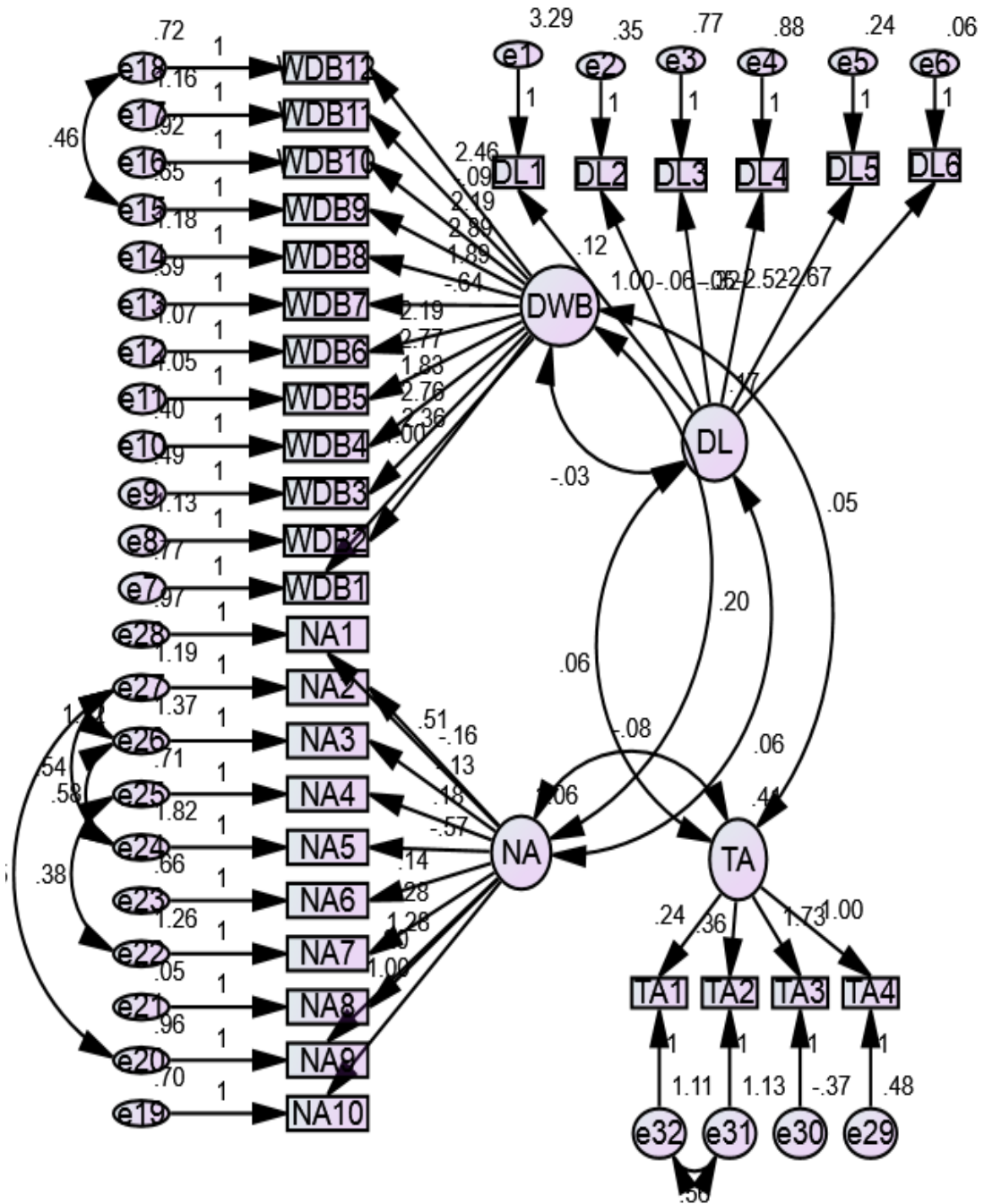

FIGURE 4.1: CFA, full measurement model (AMOS 20 output).

become .05, which is indicated moderate value in the threshold estimates and is acceptable. Initial value of the IFI was less than .90 which is not acceptable but after joining the higher values error terms the value of IFI become .90. Which is lies in the threshold estimates and are acceptable. Tucker Lewis Index (TLI) was initially unacceptable and was lesser than threshold estimate but after correlate the error terms the value becomes acceptable and lies between in the threshold estimates (TLI = .89). Comparative fit index (CFI) was initially less than .80 which is indicated bad value in the threshold table and is unacceptable. After joining the error terms the value of CFI become greater than .80 (CFI = .90) as shown in Table 4.3 2nd row, which lies between threshold estimates and becomes acceptable. So from all of the above value which can be seen in Table 4.3 are lies between threshold estimates, so our model fit is good and reliable. But we have to compare it with other models like 3 factor models, 2 factors models and 1 factor model. For 3, 2 and 1 factor models comparison following Table 4.4 is applicable.

### 4.3.1 Alternate Competing Models

TABLE 4.4: CFA Results.

Model Fit Factors	CMIN/DF	RMSEA	IFI	TLI	CFI
3 Factor DL-AR	4.9	.12	.72	.68	.72
2 Factor DL-AR, TA-EP	5.7	1.3	.66	.66	.62
1 Factor	5.8	1.3	.65	.62	.61

Seen from Table 4.4, when we reduced the model to three factor model then the values of the 3 factor models (CMIN/df = 4.9, RMSEA = .12, IFI = .72, TLI = .68 and CFI = .72) is not lies between threshold estimates. This means that our 4 factor model fit is good, because when we reduced the model to 3 factor then the values deteriorating from the threshold estimates. In the 2 factor model the values is further deteriorating (CMIN/df = 5.7, RMSEA = 1.3, IFI = .66, TLI = .66 and CFI = .62) from the threshold estimates, and the result shown that fitness of the model become bad when we reduced the model to 2 factor. At last when all the items are carry in one variable then the value (CMIN/df = 5.8, RMSEA =

1.3, IFI = .65, TLI = .62 and CFI = .61) is deteriorating more than 2 and 3 factor model, so factor 1 model is also not fit for our analysis. So from the comparison of 1, 2, 3 and 4 factor models we observe that 4 factor model is fit for our analysis and is confirm that it is valid and reliable.

## 4.4 Correlation Analysis

Correlation analysis shows relationship between two variables. Correlation analysis is performed to check weather variation between two variables differs from each other at the same time or not. Correlation analysis indicates relation between variables which is indicated by level of significance and direction of the relation which is indicated by positive or negative sign. Positive sign shows that two variables are moving in same direction, while negative sign shows that the two variables are moving in opposite direction. To determine dependence between two variables we use Pearson correlation to compute correlation coefficients. The values of correlation coefficients lie between -1 to +1. While zero value of coefficient indicates no correlation between variables.

TABLE 4.5: Correlation Analysis.

Variable	1.	2.	3.	4.	5.	6.	7.
Age	1	-	-	-	-	-	-
Qualification	0.271*	1	-	-	-	-	-
Experience	.280**	0.117	1	-	-	-	-
Despotic Leader	.202**	0.07	.279**	1	-	-	-
Negative Affectivity	0.016	0.008	0.152	.255**	1	-	-
Workplace Deviant Behaviors	-0.06	0.149	.185*	.388**	.419**	1	-
Trait Anxiety	0.004	-0.019	0.032	.260**	0.43**	.291**	1

Correlation analysis between the study variables i.e. Gender, Age, Qualification Experience, Despotic leadership, Negative Affectivity, Deviant Workplace Behavior and Trait anxiety are depict in Table 4.5. As seen from the table age is significantly positively correlated to experience ( $r = 0.280^{**}$ ,  $p < 0.01$ ), despotic

leadership ( $r = -.202^{**}$ ,  $p = .619$ ), negative affectivity ( $r = .084$ ,  $p = .184$ ), Deviant workplace behaviour ( $r = .021$ ,  $p = .742$ ) and trait anxiety ( $r = .072$ ,  $p = .258$ ). Age is significantly positively correlated with qualification ( $r = .271^{**}$ ,  $p < .01$ ) and experience ( $r = .280^{**}$ ,  $p < .01$ ) and are uncorrelated with despotic leadership ( $r = -.078$ ,  $p = .215$ ), Negative affectivity ( $r = .016$ ,  $p = .657$ ), deviant workplace behaviour ( $r = -.06$ ,  $p = .471$ ) and trait anxiety ( $r = .045$ ,  $p = .481$ ). Qualification is significantly positively correlated with Experience ( $r = .280^{**}$ ,  $p < .01$ ) and have positive sign which means the variables are moving in same direction, while it is uncorrelated with despotic leadership ( $r = .02$ ,  $p = .971$ ), negative affectivity ( $r = .014$ ,  $p = .829$ ), employee performance ( $r = .021$ ,  $p = .736$ ) and trait anxiety ( $r = .004$ ,  $p = .953$ ). Experience is not correlated with negative affectivity ( $r = .152$ ,  $p < .4$ ) and are uncorrelated with other variable i-e despotic leadership ( $r = .019$ ,  $p = .763$ ), deviant workplace behaviour ( $r = .097$ ,  $p = .124$ ) and trait anxiety ( $r = .61$ ,  $p = .337$ ).

Despotic leadership is significantly positively correlated with negative affectivity ( $r = .255^{**}$ ,  $p < .01$ ) and trait anxiety ( $r = .260^{**}$ ,  $p < .01$ ) as well as with deviant workplace behaviour ( $r = 0.388^{**}$ ,  $p = .001$ ). negative affectivity is significantly positively correlated with both employee performance ( $r = .175^{**}$ ,  $p < .01$ ) and trait anxiety ( $r = .389$ ,  $p < .01$ ). Finally deviant workplace behaviors significantly positively correlated with trait anxiety ( $r = .291^{**}$ ,  $p < .01$ ).

## 4.5 Regression Analysis

Correlation analysis is done to find out the link between variables. Correlation analysis does not show casual relationship between variables it only shows existence between two variables. For causal relationship between variable we had done regression analysis in the study. Regression analysis is used to predict and estimate relationship between variables. From the value of variable X regression analysis predict the value of Y. It helps to understand when one unit change occurs in independent variable then how much variation occurs in the dependent

variable. Hence, we have to performed regression analysis to get accurate result of dependence among variable.

For regression analysis different methods and tools are used, in previous studies Baron & Kenny (1986) method is used, but in this study we will use Preacher & Hayes (2012) method. According to Preacher & Hayes (2012), the Baron & Kenny (1986) method is outdated, because it tells about condition only of fully mediation of variable, while other researcher Preacher & Hayes (2012) tells that there should be also partially, medium level mediation because there must be other variables that can mediate the relationship between two variables.

According to Preacher and Hayes (2012) mediation can also be exist even direct relation between independent and dependent variable does not exist. In contrast Baron & Kenny (1986) tells that direct relation must be significant for mediation effect. As in the social sciences research data is always problematic because we collect data from different condition, situation and nature of respondents. So in preacher and Hayes (2012) method bootstrapping techniques used, in which the data is divided into small pieces and bits which increases likeability and realistic of the data. So we will run our analysis in this smaller level sub sample.

**H<sub>1</sub>: Despotic leadership is positively related with deviant workplace behavior.**

TABLE 4.6: Regression Analysis for Direct Effect on deviant workplace behavior.

Variables	B	SE	T	P
Despotic Leadership → Deviant Workplace Behavior	.442	.084	5.50	.0000

*\*p < .05, \*\*p < .01, \*\*\*p < .001*

As seen from Table 4.6 the result of regression analysis show that despotic leadership positively influence employee work performance (B = .442, t = 5.50 and P < .001). The first hypothesis is accepted because both the variables are moving in the same direction. When increase effect of despotic leadership the deviant

behaviour is also increases. Despotic leadership bring positive change in deviant work behaviour up to 44%. The relation is significant because p-value is less than .001.

**H<sub>2</sub>: Negative affectivity will mediate the relationship between despotic leadership and Deviant workplace behaviors.**

From Table 4.7 it is evident that the mean indirect effect of despotic leadership on employee performance through a mediating role of Negative affectivity is significant. Because the value of lower level confidence interval (LLCI) and upper level confidence interval (ULCI) has same sign (LLCI = .259 & ULCI = 1.213). According to Preacher and Hayes (2012) when the sign of LLCI and ULCI are same or no zero among the limits then the hypothesis is significant. Hence, by following Preacher and Hayes (2012) concept our hypothesis “negative affectivity mediates the relationship between despotic leadership and deviant workplace behaviour” is accepted. We can argue that negative affectivity is fully mediated the relationship between despotic leadership and deviant workplace behavior. because direct relation of our study is not significant, so by follow Preacher and Hayes (2012) role we argue that negative affectivity fully mediate the relationship.

TABLE 4.7: Regression analysis for Mediation.

Effect of IV on M		Effect of M on DV		Direct Effect of IV on DV in presence of M		Total Effect of IV on DV		Bootstrap Results for Indirect Effect	
B	t	B	t	B	t	B	t	LL 95% CI	UL 95% CI
-1.5629	-2.3783	.4035	4.6267	.4677	4.2716	.4677	4.2716	.259	1.213

\*\* $P < .05$

**H<sub>3</sub>: Trait anxiety moderates the relationship between despotic leadership and negative affectivity.**

TABLE 4.8: Regression Analysis for Moderation.

Predictors	B	SE	t	p
Constant	6.97	1.45	4.79	.000
Despotic Leadership $\times$ Trait Anxiety	0.4821	.167	2.88	.004

\* $p < .05$ , \*\* $p < .01$ , \*\*\* $p < .001$

The same is also supported from moderation graph in Figure 4.2.

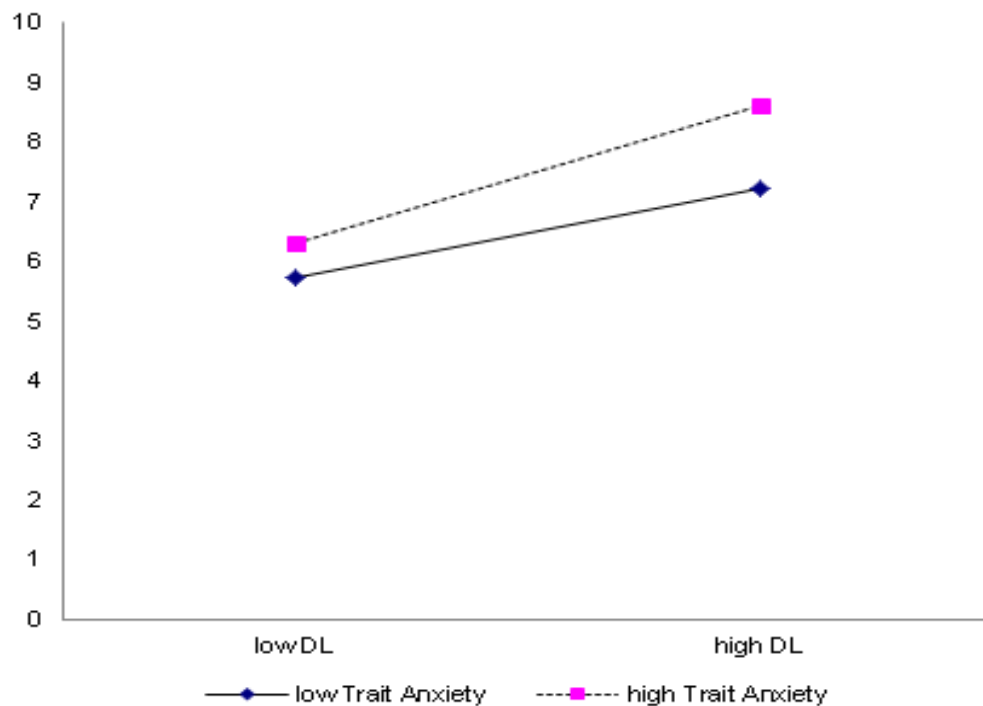

FIGURE 4.2: Moderation graph.

Upward slope of the lines indicate a positive relationship between despotic leadership and negative affectivity. The dotted line represents high trait anxiety whereas bold line reflects its intensity as low. Position and slope of the lines represents the strength of the relationship between despotic leadership and negative affectivity. As dotted line lies above the bold line with steeper slope, it represents that in case of high trait anxiety, the relationship between despotic leadership and negative affectivity becomes stronger. The graph clarifies the enhancing role and direction of trait anxiety between despotic leadership and negative affectivity which gives an additional support for the acceptance of hypothesis 3.

TABLE 4.9: Summary of Hypotheses.

No.	Hypothesis Statement	Results
H <sub>1</sub>	Despotic leadership positively related with deviant work place behavior	<b>Accepted</b>
H <sub>2</sub>	Negative affectivity mediates the relationship between despotic leadership and deviant workplace behavior	<b>Accepted</b>
H <sub>3</sub>	Trait anxiety moderate the relationship between despotic leadership and negative affectivity in such a way the relationship will be stronger with high trait anxiety than lower	<b>Accepted</b>



# Chapter 5

## Discussion, Implications, Limitations, Recommendations and Conclusion

### 5.1 Discussion

The essential focused of the study was to evaluate the relationship between Despotic leadership and deviant workplace behavior. Moreover, the mediating role of negative affectivity and moderating part inside Trait anxiety was also the emphasis of this study. This part of the study will observe the results testified in chapter-4 as highlighted earlier on the basis of different statistical procedures and analysis with the use of SPSS. Principally this chapter will emphasis to assess and clarify the reported results and consequent relationships. It will also elegant and explain the described relationships with earlier research studies, to find out the reliabilities and nonconformities among the numerous ideas. The previous exposed research queries will guide the discussion under the proposed hypothesis, for the study to reach the possible implications.

### **5.1.1 Discussion on Research Question No. 1**

**Question 1:** Does Despotic leadership affect workplace deviant behaviors of employees?

*For finding the answer to the 1st question,*

**H1: Despotic leadership will be positively related to workplace deviant behaviors.**

The findings of this study supported that First hypothesis, proposed that Despotic leadership will be positively related workplace deviant behaviors. Earlier researchers have highlighted that existence of negative behaviors and interpersonal mistreatment (Sakurai & Jex, 2012). The recent past has shown considerable studies focusing more on negative aspects of supervision role and its impact using diverse outcomes (Tepper, 2009). Despotic behaviour raise negative states, and if perceived threatening and challenging over a period of time, may results in unwanted attitudes and behaviors (Rai & Agarwal, 2017). Based on the findings of earlier studies, deviant workplace behavior exists at all managerial ranks and based on various reviews, researcher have stressed for concentration on behavioral outcomes of deviant workplace behaviour (Saima, Usman, Fauzia Syed & Dave, 2018).

Past studies have concluded that there is positive relationship between deviant workplace behavior and workplace deviant, antisocial and retaliatory behaviors. Deviant workplace behavior has been studied in many forms including abusive supervision, (Tepper, Moss, & Duffy, 2011), social undermining and incivility that includes the purpose to victimize others (Hershcovis, 2011). In this perspective, research investigating the negative impact of interpersonal mistreatment at work have shown that abusive supervision intimidate employees to react with deviant behaviors (Gregory et al., 2013). Frustration has been found a source of antisocial behavior (Fox and Spector, 1999) and continuous victimization has also been found to create retaliatory behavior and workplace deviant behaviors (Kluemper et al., 2018). Interpersonal aggression was found highly associated with deviant behavior at workplace (Hershcovis et al., 2012).

The first hypothesis in our study has been supported by the results. Our findings are thus in line with the earlier projected implications that, exposure to aggressive treatment leadsto increased retaliatory behaviors (Saima, Usman, Fauzia Syed & Dave, 2018). The study conducted by Siama et al. (2018), mentionedthat employees who are being bullied with reciprocate the negative mistreatment by demonstrating organizationally retaliatory behaviors.

Human resource is the pivotal asset of an organization and employees therefore are the key actors in gaining competitive edge to achieve organizational goals. The presence of negative interpersonal behaviors distract employees from achieving these goals as their energies are partially consumed in dealing with such behaviors. On the other hand negative events in the workplace tend to induce their intension to proceed with anti-organizational activities in the form of deviant behaviors. The earlier studies on the behavioral outcome of interpersonal mistreatment has shown association between aggression and workplace deviant behaviors and it is argued that the power imbalance molds and divert the deviant responses of the victims according to the nature of consequences being expected as a result of retaliatory behaviors (Hershcovis et al 2012).

Results of negative leadership on dissimilar groups studied in previous research contain affectivities, strain, welfare, and performing. In the background of rude understanding and results, affectivities is normally used as a control variable (Breux, Perrewe, Hall, Frink, & Hochwarter, 2008). Harsh leadership is commonly originate to be totally related to negative affectivity (Tepper et al., 2004) and adversely related to positive affectivity (Wu & Hu, 2009).

It has also been found by the earlier studies that the repeated attempts of negative treatment in the form of despotic leadership cause pressure, intimidation and anxiety to the victims (Einarsen, 2000) and such situations create a vicious cycle of tiresome negative behaviors, where the victims of despotic being threatened may target others through their interpersonal mistreatment (Zapf & Einarsen, 2003). At both these scenarios the loss is ultimately faced by organization in the form of violation of norms, reduced performance, reduced commitment and subsequent financial losses both implicit and explicit in the organizational documents. This

is the reason why, deviant workplace behavior has gain attention in the last few decades and its outcomes are studied in depth for possible remedial measures. Deviant workplace behaviour plays a pivotal role to induce workplace deviant and anti-social behaviors, which in return can hinder improvement and profit for an organization.

The current study is conducted in Pakistan and as highlighted by earlier researchers from the perspective of cultural variables, having high power distance, masculinity and collectivism, the conditions are potentially favorable for workplace bullying (Saima, Usman, Fauzia Syed & Dave, 2018). The project based-organization e.g. red cross are more specifically a subset of the society and true representative in this regard as they are operated by policies and procedures at local level, without any significance influence of private or multinational dimensions. Therefore as marked by the employees of various project based-organization e.g. red cross that they face bullying behaviors, is considered consistent with the earlier findings. Earlier research has highlighted a number of factors as antecedents of workplace deviant behaviors including deviance as reaction to negative experiences at work, personality features and social context (Bennett and Robinson, 2003), and as depicted in our study the said relationship has been found in consistency with previous research findings.

### **5.1.2 Discussion on Research Question No. 2**

**Question 2:** Does negative affectivity mediates the relationship between deviant workplace behaviour and workplace deviant behaviors?

*For finding the answer to the 2nd question,*

**H2: Negative Affectivity will mediate the relationship between despotic leadership and workplace deviance behaviors.**

The findings of this study supported the second hypothesis, proposed that Negative Affectivity will mediate the relationship between Despotic leadership and workplace deviance behaviors.

The findings of the present study supported the proposed mediation hypothesis. We found that negative affectivity mediated the relationship between Despotic leadership and workplace deviant behaviors, which are consistent with findings of previous research shown that affective responses (emotions) are prospective mediators (Rai and Agarwal, 2017) and negative emotions are converted to unwanted attitude & behaviors. In this perspective, in the presence of Despotic behaviors at workplace, interpersonal mistreatment will induce negative affectivity in the target. This enhancement in adverse effects as indicated by negative affectivity will increase employee's tendency to get involved in workplace deviant behaviors. From another perspective and in addition to considering negative impact caused by an bullying behavior, this results suggest that in term of emotional connectivity employees are susceptible to the negative events of the environment and such effects are subsequently compensated with deviant behaviors at workplace.

Past research studies have shown that Despotic behaviors are translated to high level of negative emotions which resultantly lead to detrimental outcomes for the exposed victims (Ursin and Eriksen, 2004). The consistent negative behaviors of perpetrator tends to produce negative affect in victims and more susceptible individuals respond with enhanced negative emotional states, and are thus more vulnerable physical sickness (Watson, 2000). It has also been found that individuals who are characterized scared, anxious and sad are more prone victims to possible perpetrators (Samnani and Singh, 2012) and that experiences of undesirable events can add significantly to negative affectivity (George, 1995). However very little attention been paid by research, studying the emotional state of negative affectivity in relationship to Despotic leadership and/or deviant behavior as outcome.

Negative affectivity has formerly been clear as a constant attribute that returns the trend to skill negative feeling and grief across situations and even in the time off of objective stressors (Watson and Clark 1984, Watson et al. 1987). It has remained discussed by some professional strain researchers that negative affectivity may develop associations between self-reported stressors and anxiety, so operative as a applied distress (Brief et al. 1988). Not startlingly, significant research and debate

has been created over the practical irritant properties of negative affectivity (Brief et al. 1988, Burke et al. 1993, Chen and Spector 1991, Jex) and (Spector 1996, Schaubroeck et al. 1992).

In the line with our integrative frame work, earlier research have shown consistent results linking undesirable events with negative emotional states, psychological & emotional adjustments and ultimate undesirable outcomes. Despotic leadership has been associated with emotional adjustments besides other detrimental effects (Ttofi et al., 2016) and in the framework of affective state earlier research has found that psychological linkages and stimulation exist, where individual differences play a part in translating the outcomes of emotional states to undesirable counterproductive behaviors (Penney And Spector, 2005). Hence it is has also been found that a person who is characterized scared, anxious and sad is considered to be more prone victims to possible perpetrators(Samnani and Singh, 2012).

The consistent negative behaviors of perpetrator tends to produce negative affect in victims and more susceptible individuals respond with enhanced negative emotional states, and are thus more vulnerable physical sickness (Watson, 2000). Negative affectivity was found highly correlated with despotic exposure and it has been argued that experience of despotic and negative affectivity state intermingle in a spiteful loop of occurrences, hence interpersonal mistreatment may provoke high level of discomfort in victims ; and resultantly they will behave aggressively towards others with negative attitudes (Mikkelsen and Einarsen, 2002).

Several researcher have found that negative affectivity impacts thinking pattern of individuals towards the given environment and individuals high in NA are more prone to stressful situations (Stoeva, Chiu and Greenhaus, 2002). While the study of personality has been suggested earlier under the domain of person-situation view, it is argued that dispositional variables like negative affectivity and locus of control may be explored in further refining the relationship (Naseer, S et al., 2016). When faced with stressful events, where the intention to damage is evident, individuals high in negative affectivity will attribute more hateful drives to the perpetrator, thereby increasing their psychological arousal and subsequent negative behaviors. For individuals with low negative affectivity the opposite will

apply, where the negative experience will be neutralized with positive benevolent attributions, thus their feelings to respond negatively will be restricted (Penney And Spector, 2005).

In the current study we have found that despotic leadership will enhance negative affectivity of the victims of despotic. In such poisoned interpersonal environment, the target of despotic will feel hurt, sad and anxious and therefore may engaged in deviant work behaviors. Their tendency of pro-organizational positive behaviors may be reduced and they may act inappropriately. Therefore our second hypothesis is supported by the findings of the current study.

### **5.1.3 Discussion on Research Question No. 3**

**Question 3:** Does Trait anxiety moderates the relationship between despotic leadership and negative affectivity?

*For finding the answer to the 3rd question,*

**H3: Trait anxiety moderates the relationship between Despotic leadership and Negative Affectivity, such that the relationship will be weaken when trait anxiety is high.**

This findings of the current study supports the third hypothesis of moderation that is trait anxiety moderates the relationship between despotic leadership and negative affectivity. Earlier research studies have recognized the pivotal part of individual differences in explaining and determining despotic leadership, as shown that personal dispositional traits act as moderator within despotic leadership-outcomes relationship (Moreno-Jimenez et al., 2009). In this perspective one of the key personal characteristic trait anxiety has gained very less attention in despotic research (Rai and Agarwal, 2017).

In this perspective earlier studies have shown that behavior is outcome of sequences of cognitive and emotional processes, and individual differences have an obvious standing in the process, research on despotic leadership has focused on underlying path leading to these outcomes. Trait anxiety give individual the strength and confidence to divert the negative impacts of negative life events (Connolly, 1980),

therefore individual with high level of trait anxiety will think and behave negatively. Given the fact that cognitive capabilities have been found as influencer of deviant behaviors to supervisory mistreatment (Kluemper et al., 2018), trait anxiety will moderate the impact of despotic leadership, resulting in higher negative affectivity and subsequent deviant behaviors at workplace.

In this regard it is also highlighted that consequences of stressful situations have linkages with individual judgment and coping capability. Therefore individual variances in the target evaluation with reference to despotic behaviors may be considered an explanation as why different individuals respond differently to such behaviors (Mikkelsen and Einarsen, 2002). Derived from the fact that exposure to despotic leadership has not equal effect on all individuals, dispositional factors are central factors in the relationship of deviant workplace behaviour and outcomes (Moreno-Jiménez, et al. 2009). Despotic leadership therefore will depend on how the negative behaviors will be perceived and how individual will attribute it internally (to self) or externally (to outside forces). A number of earlier studies have reflected that dispositional factors are associated with despotic leadership and differences exist between victims and non-victims (Zapf & Einarsen, 2003).

The concept perceived anxiety has been widely studied, as it is found that anxiety of belief is linked with a number of psychological and behavioral outcomes (to include cognitive, affective, actions) and based on personal experience, individuals have the different dispositional tendency to believe that they can anxiety over environment. This fact has defined the way some individuals are unable to observe the linkage between their actions and outcomes (external), while others have the lasting belief that consequences are functions their actions, (Ng, Sorensen, & Eby, 2006).

Those with high trait anxiety observe high linkage between actions and consequences; and having the approach that they are the masters of their fate are assertive, attentive, and are commanding position to regulate their external environments. LOC has been found associated behavioral orientation, and a mental exposure of keeping vigorous behavioral regulation, are further related to social experiences and coping behaviors. Positive self-evaluation on the other hand will



provide motivation to affirm vigorous behavioral control through positive emotional regulations (Ng, Sorensen, & Eby, 2006). Individual having internals focus on their self-efforts and abilities, also put their energies in the direction of personal goals, and subordinate employees high in trait anxiety pay lesser attention to and are less amenable of their supervisors' influence (Ng, Sorensen, & Eby, 2006), thus the self-regulatory actions and emotions may act as a buffer to the negative enforcement of the supervisor.

Previously it has also been established that trait behaviors enhance the capabilities of individuals to cope with negative environmental factors and events, and as control has been linked with active coping strategies as it involves cognitive assessment followed by proactive behaviors, (Dijkstra, Beersma and Evers, 1977), the internality will help the individuals to think and feel positive even in the occurrence of negative events. Since work place bullying has negative implications (just like any stressor), trait anxiety will influence the relationship between bullying and corresponding deviant behaviors, by buffering the negative emotions. Hence, it is found that individual with high level of trait anxiety will behave positively, thereby mitigating the negative effects as result of deviant workplace behaviour and consequently will act positively and favorably for organization.

## **5.2 Implications and Recommendations**

### **5.2.1 Theoretical Implications**

There are many theoretical implications of the current study, which are discussed below:

Firstly, the present study investigated the relationship between Despotic leadership and workplace deviant behaviours. Earlier, limited studied are available related to behavioral outcomes and workplace deviant behaviour is a new area of study and contribution of our study.

Secondly , the role of emotional and affective states have been studied earlier as mediating factor in despotic leadership outcome relationship , however negative

affectivity as an emotional state has not been studied earlier in the Pakistani context with specific consideration of public sector employees, therefore this study has contributed as how deviant workplace behaviour effect negative affectivity of the victim.

Thirdly, on the role of dispositional factors as moderator between despotic leadership and negative affectivity, we found no studies in general and therefore is the contribution of the current study.

Fourthly, the present study extended and supported the underlying theoretical assumptions of Affective Event Theory (AET), describing that work actions and environment affect the sentiments of employees and these feelings further lead them to perform and counter (Weiss & Cropanzano 1996). According to this theory Work environment provides the platform where attitudes are influenced through affective path ,thus hassles and uplifts are translated to either positive or negative affective responses, which resultantly lead to corresponding negative or positive behaviors. Hence it's obvious that any component or action of the environment within work domain has positive or negative implication on corresponding emotions and subsequent behavior. The findings of our investigations, therefore has alignment and support to the theoretical foundations of AET.

Finally, our study has contributed by investigating the integrative framework, comprising of despotic – deviant behaviors relationship under the moderating effect of trait anxiety as personal trait which has not been studied jointly by earlier research in the context despotic.

### **5.2.2 Practical Implications**

The current study has some important implications for public sectors organizations in Pakistan.

The concept of despotic leadership has very little attention being paid by such organizations, despite the fact that despotic leadership exists at all level of organizations. The main factor may be that such events are not properly reported due to various factors. Given that consequences of bullying at workplace include several

detrimental effects, organizations may take actions to curb its tendency. A typical measure which may be adopted to include, policies and procedures to handle the reported negative behaviors. Employees may be encouraged to report incidents of despotic at appropriate forums to highlight the issues and perpetrators, with the assurance to safeguard the interests of the victims.

Secondly, given the fact that personal dispositional and effective states of the individuals molds the outcomes of the despotic at either positive or negative directions, it is imperative for the organizations to re-visit the selection criteria. Investigating and establishing the fact that employee with low level of trait anxiety under the state of enhanced negative affectivity are more prone to negative impacts of despotic, this study is of particular importance. Focusing on the selection of psychologically and emotionally suitable candidates will help to avoid many of the curses of deviant workplace behaviour both from the perspective of perpetrator and victims. For instance organization may imply the yardstick of personal traits by assessment through psychological evaluation, while selecting potential candidates for employment as per nature of job and working environment.

For the existing held employees the organizations may adopt intervention strategies to minimize the effects of negative behaviors. Organization may also take up several interventions strategies and advance level training programmes for employees to develop their personal capabilities of handling negative experiences and behaviors (Rai and Agarwal, 2017). Generally the occurrence of bullying has the downward orientation and therefore, appraisal measures (like 360 degree approach) may be helpful tool in gaining the assessment of supervisors in term of behaviors towards subordinate staff. Additionally counselling desk at HR Departments will help in positive orientations of both supervisory and subordinate staff, with respect to creating conducive work environment.

### **5.3 Limitations**

This study has few limitations, beside the fact that within the available resources all necessary efforts were made to meet the desired standards of professional research.

Firstly, due to time limitations the study has been piloted with cross sectional mode instead of longitudinal frame of time horizon, which requires more time and resources. Response on despotic leadership has been obtained at one time, despite the facts that there exists ample possibility that the level of experience and exposure by employees may have different levels according to the time frame. The cycle of repeated observations would be suitable to test the trend of exposure to despotic leadership. The application of time lag for six months or more would be more suitable as despotic leadership consist of repeated negative actions over a period of time.

Secondly, the scope of the current study was limited to individuals serving in public sector organization of Pakistan. This limitation in scope may reduce the application of the findings of the study with respect to the other key employment sectors. Addition of other major private businesses and private organizations for example, commercial banks, NGO, S, software companies, INGO, S, may enhance the testing and significance of the results. It's obvious that type of organization will affect the results due to difference in working environment. For instance the level of despotic exposures in service industries having challenging and deadline specific activities will be more as compare to a manufacturing unit where routine work does not involve public dealings or strict deadlines.

Thirdly, due to resource limitations, convenience sampling technique was used for the data sampling in the present study. Moreover the sample size was quite very small, and may not represent the bullied employees in Pakistani organizations. Large sample size increases the generalizability of the results and its applicability in a wider situation.

## **5.4 Conclusion**

The concept of despotic leadership has extended much attention over a period of time due to its negative effects over employees and organizations. While studies on behavioral outcomes of despotic leadership are the call of researchers, understanding the role of dispositional factors and emotional states of individuals is equally imperative to investigate and expand the concept further. The purpose of this study was to investigate the relationship between despotic leadership and workplace deviant behaviors within an integrative framework under the underpinning assumptions of AET theory. The study, within the given framework tested the mediating effect of negative affectivity and moderating effect of trait anxiety between despotic leadership and negative affectivity. Based on the quoted theory, the findings are in line the proposed hypothesis, explaining the role of personal dispositional traits and affective states in despotic leadership-workplace deviant behaviors relationship. Integrating the concept, in the first place, it's obvious that individuals having tendency of high negative affectivity towards negative work events are more prone to act negatively and respond with deviant behaviors which resultantly are costly for the organizations. On the other hand the tendency of high level of trait anxiety help individuals to regulate their sensitive and behavioral response towards negative events at workplace. The study was conducted in project based-organization e.g. red crossin Pakistan. Due to cultural factors, Pakistani working environment has more tendency for employees to be despoiled . Still, due to lake of skilled awareness of the concept and reporting mechanism, employees don't find suitable forum for demonstration. The results of the current study are reliable with earlier studies and finally employees with despotic disclosures will tend to react negatively with deviant behaviors at workplace.

# Bibliography

- Amabile, T. M. (1988). A model of creativity and innovation in organizations. *Research in Organizational Behavior*, 10(1), 123-167.
- Aquino, K., Lewis, M. U., & Bradfield, M. (1999). Justice constructs, negative affectivity, and employee deviance: A proposed model and empirical test. *Journal of Organizational Behavior*, 20(7), 1073-1091.
- Aronson, E. (2001). Integrating leadership styles and ethical perspectives. *Canadian Journal of Administrative Sciences/Revue Canadienne des Sciences de l'Administration*, 18(4), 244-256.
- Ashforth, B. (1994). Petty tyranny in organizations. *Human Relations*, 47(7), 755-778.
- Ashforth, B. E. (1997). Petty tyranny in organizations: A preliminary examination of antecedents and consequences. *Canadian Journal of Administrative Sciences/Revue Canadienne des Sciences de l'Administration*, 14(2), 126-140.
- Avey, J. B., Wernsing, T. S., & Luthans, F. (2008). Can positive employees help positive organizational change? Impact of psychological capital and emotions on relevant attitudes and behaviors. *The Journal of Applied Behavioral Science*, 44(1), 48-70.
- BarNir, A., Watson, W. E., & Hutchins, H. M. (2011). Mediation and moderated mediation in the relationship among role models, self-efficacy, entrepreneurial career intention, and gender. *Journal of Applied Social Psychology*, 41(2), 270-297.
- Baron, R. A., & Neuman, J. H. (1996). Workplace violence and workplace aggression: Evidence on their relative frequency and potential causes. *Aggressive*

- Behavior: Official Journal of the International Society for Research on Aggression*, 22(3), 161-173.
- Bartels, S. A., Scott, J. A., Mukwege, D., Lipton, R. I., VanRooyen, M. J., & Leaning, J. (2010). Patterns of sexual violence in Eastern Democratic Republic of Congo: reports from survivors presenting to Panzi Hospital in 2006. *Conflict and Health*, 4(1), 9-14
- Bass, B. M. (1990). From transactional to transformational leadership: Learning to share the vision. *Organizational Dynamics*, 18(3), 19-31.
- Bennett, R. J., & Robinson, S. L. (2000). Development of a measure of workplace deviance. *Journal of Applied Psychology*, 85(3), 349-356
- Bennett, R. J., & Robinson, S. L. (2003). The past, present, and future of workplace deviance research.
- Bies, R. J., & Moag, J. S. (1986). Interactional communication criteria of fairness. *Research in Organizational Behavior*, 9, 289-319.
- Bies, R. J., & Tripp, T. M. (1998). Revenge in organizations: The good, the bad, and the ugly.
- Bligh, M. C., Kohles, J. C., Pearce, C. L., Justin, J. E., & Stovall, J. F. (2007). When the romance is over: Follower perspectives of aversive leadership. *Applied Psychology*, 56(4), 528-557.
- Breaux, D. M., Perrewé, P. L., Hall, A. T., Frink, D. D., & Hochwarter, W. A. (2008). Time to try a little tenderness? The detrimental effects of accountability when coupled with abusive supervision. *Journal of Leadership & Organizational Studies*, 15(2), 111-122.
- Brief, A. P., Burke, M. J., George, J. M., Robinson, B. S., & Webster, J. (1988). Should negative affectivity remain an unmeasured variable in the study of job stress? *Journal of Applied Psychology*, 73(2), 193-201.
- Brown, M. E., & Treviño, L. K. (2006). Ethical leadership: A review and future directions. *The Leadership Quarterly*, 17(6), 595-616.

- Burke, D. H., Raubeson, L. A., Alberti, M., Hearst, J. E., Jordan, E. T., Kirch, S. A., . . . & Stein, D. B. (1993). The chlL (frxC) gene: Phylogenetic distribution in vascular plants and DNA sequence from *Polystichum macrostichoides* (Pteridophyta) and *Synechococcus* sp. 7002 (Cyanobacteria). *Plant Systematics and Evolution*, 187(1-4), 89-102.
- Buunk, A. P., Peiró, J. M., & Griffioen, C. (2007). A Positive Role Model May Stimulate Career Oriented Behavior 1. *Journal of Applied Social Psychology*, 37(7), 1489-1500.
- Byrne, D. (1961). Interpersonal attraction and attitude similarity. *The Journal of Abnormal and Social Psychology*, 62(3), 713-721
- Chen, P. Y., & Spector, P. E. (1991). Negative affectivity as the underlying cause of correlations between stressors and strains. *Journal of Applied Psychology*, 76(3), 398-406
- Clark, M. S. (1984). Record keeping in two types of relationships. *Journal of Personality and Social Psychology*, 47(3), 549-557
- Coccia, C. (1998). Avoiding a "toxic" organization. *Nursing Management*, 29(5), 32-33.
- Colbert, A. E., Mount, M. K., Harter, J. K., Witt, L. A., & Barrick, M. R. (2004). Interactive effects of personality and perceptions of the work situation on workplace deviance. *Journal of Applied Psychology*, 89(4), 599-609
- Conger, J. A. (1990). The dark side of leadership. *Organizational Dynamics*, 19(2), 44-55.
- Cortina, L. M., Magley, V. J., Williams, J. H., & Langhout, R. D. (2001). Incivility in the workplace: incidence and impact. *Journal of Occupational Health Psychology*, 6(1), 64-73
- Coyne, I., Seigne, E., & Randall, P. (2000). Predicting workplace victim status from personality. *European Journal of Work and Organizational Psychology*, 9(3), 335-349.



- Davies, R. J., Ali, N. J., & Stradling, J. R. (1992). Neck circumference and other clinical features in the diagnosis of the obstructive sleep apnoea syndrome. *Thorax*, 47(2), 101-105.
- De Hoogh, A. H., & Den Hartog, D. N. (2008). Ethical and despotic leadership, relationships with leader's social responsibility, top management team effectiveness and subordinates' optimism: A multi-method study. *The Leadership Quarterly*, 19(3), 297-311.
- Dirks, K. T., & Ferrin, D. L. (2002). Trust in leadership: Meta-analytic findings and implications for research and practice. *Journal of Applied Psychology*, 87(4), 611-617
- Duffy, M. K., & Ferrier, W. J. (2003). Birds of a feather...? How supervisor-subordinate dissimilarity moderates the influence of supervisor behaviors on workplace attitudes. *Group & Organization Management*, 28(2), 217-248.
- Einarsen, S., Aasland, M. S., & Skogstad, A. (2007). Destructive leadership behaviour: A definition and conceptual model. *The Leadership Quarterly*, 18(3), 207-216.
- Engelbrecht, A. S., Wolmarans, J., & Mahembe, B. (2017). Effect of ethical leadership and climate on effectiveness. *SA Journal of Human Resource Management*, 15(1), 1-8.
- Eysenck, S. B. G., & Eysenck, H. J. (1968). The measurement of psychoticism: a study of factor stability and reliability. *British Journal of Social and Clinical Psychology*, 7(4), 286-294.
- FoA, E. B., McNally, R., & Murdock, T. B. (1989). Anxious mood and memory. *Behaviour Research and Therapy*, 27(2), 141-147.
- Folger, R., & Skarlicki, D. P. (1998). When tough times make tough bosses: Managerial distancing as a function of layoff blame. *Academy of Management Journal*, 41(1), 79-87.
- Fox, S., & Spector, P. E. (1999). A model of work frustration-aggression. *Journal of Organizational Behavior*, 20(6), 915-931.

- Freud, S. (1936). Inhibitions, symptoms and anxiety. *The Psychoanalytic Quarterly*, 5(1), 1-28.
- Frost, H. M. (2004). A 2003 update of bone physiology and Wolff's Law for clinicians. *The Angle Orthodontist*, 74(1), 3-15.
- George, E. I. (1992). Explaining the Gibbs sampler. *The American Statistician*, 46(3), 167-174.
- Glasø, L., Matthiesen, S. B., Nielsen, M. B., & Einarsen, S. (2007). Do targets of workplace bullying portray a general victim personality profile? *Scandinavian Journal of Psychology*, 48(4), 313-319.
- Glasø, L., Vie, T., & Hoel, H. (2010). Bullying in the workplace. *Risky Business: Psychological, Physical and Financial Costs of High Risk Behavior in Organizations*, 351-374.
- Greenberg, J. M. (1998). Making a comet nucleus. *Astronomy and Astrophysics*, 330, 375.
- Griffin, W. L., Doyle, B. J., Ryan, C. G., Pearson, N. J., O'Reilly, S. Y., Natapov, L., . . . & Ward, J. (1998, April). Lithosphere structure and mantle terranes: Slave Craton, Canada. *In International Kimberlite Conference: Extended Abstracts* (Vol. 7, No. 1, pp. 271-273).
- Harrell-Cook, G., Ferris, G. R., & Dulebohn, J. H. (1999). Political behaviors as moderators of the perceptions of organizational politics—work outcomes relationships. *Journal of Organizational Behavior*, 20(7), 1093-1105.
- Herscovis, M. S., Reich, T. C., Parker, S. K., & Bozeman, J. (2012). The relationship between workplace aggression and target deviant behaviour: The moderating roles of power and task interdependence. *Work & Stress*, 26(1), 1-20.
- Hofstede, G. (2007). Asian management in the 21st century. *Asia Pacific Journal of Management*, 24(4), 411-420.
- House, R. J., & Howell, J. M. (1992). Personality and charismatic leadership. *The Leadership Quarterly*, 3(2), 81-108.

- Hulin, C. (1991). Adaptation, persistence, and commitment in organizations.
- Ivancevich, J. M., & Matteson, M. T. (1980). Optimizing human resources: a case for preventive health and stress management. *Organizational Dynamics*, 9(2), 5-25.
- Jex, S. M., & Beehr, T. A. (1991). Emerging theoretical and methodological issues in the study of work-related stress. *Research in Personnel and Human Resources Management*, 9(31), 1-365.
- Jex, S. M., & Spector, P. E. (1996). The impact of negative affectivity on stressor-strain relations: A replication and extension. *Work & Stress*, 10(1), 36-45.
- Jick, T. D., & Mitz, L. F. (1985). Sex differences in work stress. *Academy of Management Review*, 10(3), 408-420.
- Judge, T. A., & Piccolo, R. F. (2004). Transformational and transactional leadership: a meta analytic test of their relative validity. *Journal of Applied Psychology*, 89(5), 755-767
- Judge, W. Q., Fryxell, G. E., & Dooley, R. S. (1997). The new task of R&D management: creating goal-directed communities for innovation. *California Management Review*, 39(3), 72-85.
- Karakitapoğlu-Aygün, Z., & Gumusluoglu, L. (2013). The bright and dark sides of leadership: Transformational vs. non-transformational leadership in a non-Western context. *Leadership*, 9(1), 107-133.
- Knoke, D., & Prensky, D. (1984). What relevance do organization theories have for voluntary associations? *Social Science Quarterly*, 65(1), 3-9
- Lieberman, P., Nicklas, R. A., Randolph, C., Oppenheimer, J., Bernstein, D., Bernstein, J., ... & Khan, D. (2015). Anaphylaxis — A practice parameter update 2015. *Annals of Allergy, Asthma & Immunology*, 115(5), 341-384.
- Luthans, F. (2002). The need for and meaning of positive organizational behavior. *Journal of Organizational Behavior: The International Journal of Industrial, Occupational and Organizational Psychology and Behavior*, 23(6), 695-706.

- McNally, R. J., Foa, E. B., & Donnell, C. D. (1989). Memory bias for anxiety information in patients with panic disorder. *Cognition & Emotion*, 3(1), 27-44.
- Mikkelsen, E. G. E., & Einarsen, S. (2002). Basic assumptions and symptoms of post-traumatic stress among victims of bullying at work. *European Journal of Work and Organizational Psychology*, 11(1), 87-111.
- Mitchell, M. S., & Ambrose, M. L. (2007). Abusive supervision and workplace deviance and the moderating effects of negative reciprocity beliefs. *Journal of Applied Psychology*, 92(4), 1159-1164
- Mowday, R., Porter, L., & Steers, R. (1982). Organizational linkages: the psychology of commitment. *Journal of Vocational Behavior*, 14(4), 224-247.
- Mulki, J. P., Jaramillo, F., & Locander, W. B. (2006). Effects of ethical climate and supervisory trust on salesperson's job attitudes and intentions to quit. *Journal of Personal Selling & Sales Management*, 26(1), 19-26.
- Naseer, S., Raja, U., Syed, F., Donia, M. B., & Darr, W. (2016). Perils of being close to a bad leader in a bad environment: Exploring the combined effects of despotic leadership, leader member exchange, and perceived organizational politics on behaviors. *Leadership Quarterly*, 27(1), 14-33.
- Naseer, S., Raja, U., Syed, F., Donia, M. B., & Darr, W. (2016). Perils of being close to a bad leader in a bad environment: Exploring the combined effects of despotic leadership, leader member exchange, and perceived organizational politics on behaviors. *The Leadership Quarterly*, 27(1), 14-33.
- Nauman, S., Fatima, T., & Haq, I. U. (2018). Does despotic leadership harm employee family life: exploring the effects of emotional exhaustion and anxiety. *Frontiers in Psychology*, 9, 601-608
- O'Leary-Kelly, A. M., Griffin, R. W., & Glew, D. J. (1996). Organization-motivated aggression: A research framework. *Academy of Management Review*, 21(1), 225-253.
- Organ, D. W. (1988). A restatement of the satisfaction-performance hypothesis. *Journal of Management*, 14(4), 547-557.

- Padilla, A., Hogan, R., & Kaiser, R. B. (2007). The toxic triangle: Destructive leaders, susceptible followers, and conducive environments. *The Leadership Quarterly*, 18(3), 176-194.
- Podsakoff, N. P., Whiting, S. W., Podsakoff, P. M., & Blume, B. D. (2009). Individual-and organizational-level consequences of organizational citizenship behaviors: A meta analysis. *Journal of Applied Psychology*, 94(1), 122-127
- Rai, A., & Agarwal, U. A. (2017). Linking workplace bullying and work engagement: the mediating role of psychological contract violation. *South Asian Journal of Human Resources Management*, 4(1), 42-71.
- Raja, M. A. Z., Ahmed, U., Zameer, A., Kiani, A. K., & Chaudhary, N. I. (2019). Bio-inspired heuristics hybrid with sequential quadratic programming and interior-point methods for reliable treatment of economic load dispatch problem. *Neural Computing and Applications*, 31(1), 447-475.
- Robinson, S. L., & Bennett, R. J. (1995). A typology of deviant workplace behaviors: A multidimensional scaling study. *Academy of Management Journal*, 38(2), 555-572.
- Robinson, S. L., & O'Leary-Kelly, A. M. (1998). Monkey see, monkey do: The influence of work groups on the antisocial behavior of employees. *Academy of Management Journal*, 41(6), 658-672.
- Rotundo, M., & Sackett, P. R. (2002). The relative importance of task, citizenship, and counterproductive performance to global ratings of job performance: A policy-capturing approach. *Journal of Applied Psychology*, 87(1), 66-77.
- Sakurai, K., & Jex, S. M. (2012). Coworker incivility and incivility targets' work effort and counterproductive work behaviors: The moderating role of supervisor social support. *Journal of Occupational Health Psychology*, 17(2), 150-161
- Salin, D. (2003). Ways of explaining workplace bullying: A review of enabling, motivating and precipitating structures and processes in the work environment. *Human Relations*, 56(10), 1213-1232.

- Samnani, A. K., & Singh, P. (2012). 20 years of workplace bullying research: a review of the antecedents and consequences of bullying in the workplace. *Aggression and Violent Behavior, 17*(6), 581-589.
- Schaubroeck, J., Ganster, D. C., & Fox, M. L. (1992). Dispositional affect and work-related stress. *Journal of Applied Psychology, 77*(3), 322-329
- Schaubroeck, J., Walumbwa, F. O., Ganster, D. C., & Kepes, S. (2007). Destructive leader traits and the neutralizing influence of an "enriched" job. *The Leadership Quarterly, 18*(3), 236-251.
- Schilling, J. (2009). From ineffectiveness to destruction: A qualitative study on the meaning of negative leadership. *Leadership, 5*(1), 102-128.
- Schilling, M. A. (2009). Understanding the alliance data. *Strategic Management Journal, 30*(3), 233-260.
- Schneider, B. (1987). The people make the place. *Personnel Psychology, 40*(3), 437-453.
- Schneider, B., Smith, D. B., Taylor, S., & Fleenor, J. (1998). Personality and organizations: A test of the homogeneity of personality hypothesis. *Journal of Applied Psychology, 83*(3), 462-479
- Skarlicki, D. P., & Folger, R. (1997). Retaliation in the workplace: The roles of distributive, procedural, and interactional justice. *Journal of Applied Psychology, 82*(3), 434-439
- Skarlicki, D. P., Folger, R., & Tesluk, P. (1999). Personality as a moderator in the relationship between fairness and retaliation. *Academy of Management Journal, 42*(1), 100-108.
- Smidts, A., Pruyn, A. T. H., & Van Riel, C. B. (2001). The impact of employee communication and perceived external prestige on organizational identification. *Academy of Management Journal, 44*(5), 1051-1062.
- Smith, T. W., Ingram, R. E., & Brehm, S. S. (1983). Social anxiety, anxious self-preoccupation, and recall of self-relevant information. *Journal of Personality and Social Psychology, 44*(6), 1276-1283.

- Spector, P. E., & Fox, S. (2002). An emotion-centered model of voluntary work behavior: Some parallels between counterproductive work behavior and organizational citizenship behavior. *Human Resource Management Review*, 12(2), 269-292.
- Spielberger, C. D., Gorsuch, R. L., & Lushene, R. E. (1970). *Stai. Manual for the State-Trait Anxiety Inventory (Self Evaluation Questionnaire)*. *Palo Alto California: Consulting Psychologist*, 22(3), 1-24.
- Spreitzer, G. M., & Sonenshein, S. (2004). Toward the construct definition of positive deviance. *American Behavioral Scientist*, 47(6), 828-847.
- Stamper, C. L., & Johlke, M. C. (2003). The impact of perceived organizational support on the relationship between boundary spanner role stress and work outcomes. *Journal of Management*, 29(4), 569-588.
- Taylor, J. A. (1953). A personality scale of manifest anxiety. *The Journal of Abnormal and Social Psychology*, 48(2), 285-292.
- Tepper, B. J., Carr, J. C., Breaux, D. M., Geider, S., Hu, C., & Hua, W. (2009). Abusive supervision, intentions to quit, and employees' workplace deviance: A power/dependence analysis. *Organizational Behavior and Human Decision Processes*, 109(2), 156-167.
- Tepper, B. J., Duffy, M. K., & Shaw, J. D. (2001). Personality moderators of the relationship between abusive supervision and subordinates' resistance. *Journal of Applied Psychology*, 86(5), 974-980.
- Turban, D. B., & Keon, T. L. (1993). Organizational attractiveness: An interactionist perspective. *Journal of Applied Psychology*, 78(2), 184-191.
- Tyler, T. R. (1997). The psychology of legitimacy: A relational perspective on voluntary deference to authorities. *Personality and Social Psychology Review*, 1(4), 323-345.
- Ursin, H., & Eriksen, H. R. (2004). The cognitive activation theory of stress. *Psychoneuroendocrinology*, 29(5), 567-592.

- Van Knippenberg, D., & Sleebos, E. (2006). Organizational identification versus organizational commitment: self-definition, social exchange, and job attitudes. *Journal of Organizational Behavior: The International Journal of Industrial, Occupational and Organizational Psychology and Behavior*, 27(5), 571-584.
- Van Knippenberg, D., & Van Schie, E. C. (2000). Foci and correlates of organizational identification. *Journal of Occupational and Organizational Psychology*, 73(2), 137-147.
- Walumbwa, F. O., Avolio, B. J., Gardner, W. L., Wernsing, T. S., & Peterson, S. J. (2008). Authentic leadership: Development and validation of a theory-based measure. *Journal of Management*, 34(1), 89-126.
- Watson, D. (2000). Basic problems in positive mood regulation. *Psychological Inquiry*, 11(3), 205-209.
- Watson, D., & Clark, L. A. (1984). Negative affectivity: the disposition to experience aversive emotional states. *Psychological Bulletin*, 96(3), 465-471.
- Watson, D., Clark, L. A., & Carey, G. (1988). Positive and negative affectivity and their relation to anxiety and depressive disorders. *Journal of Abnormal Psychology*, 97(3), 346-356.
- Watson, D., Clark, L. A., & Tellegen, A. (1984). Cross-cultural convergence in the structure of mood: A Japanese replication and a comparison with US findings. *Journal of Personality and Social Psychology*, 47(1), 127-133.
- Watson, D., Pennebaker, J. W., & Folger, R. (1987). Beyond negative affectivity: Measuring stress and satisfaction in the workplace. *Journal of Organizational Behavior Management*, 8(2), 141-158.
- Wu, B., Hu, D., Kuang, Y., Liu, B., Zhang, X., & Chen, J. (2009). Functionalization of carbon nanotubes by an ionic-liquid polymer: dispersion of Pt and PtRu nanoparticles on carbon nanotubes and their electrocatalytic oxidation of methanol. *Angew and teChemie International Edition*, 48(26), 4751-4754.



# Appendix

Dear Participant,

I am a student of MS (PM) at Capital University of Science & Technology, Islamabad. I am conducting a research on **Impact of Despotic Leadership on Workplace Deviant Behaviors: The Mediating Role of Negative Affectivity and Moderating role of Trait Anxiety**. You can help me by completing the attached questionnaire, you will find it quite interesting. I appreciate your participation in my study and I assure that your responses will be held confidential and will only be used for education purposes.

Sincerely,

Naqeeb Tayyab

## Section A: Despotic Leadership

Please tick the relevant choice.

## Section A: Despotic Leadership

Please tick the relevant choice.

S. No.	Statements	Strongly Disagree	Disagree	Neutral	Agree	Strongly Agree
1.	Despotic leadership Is punitive; has no pity or compassion	1	2	3	4	5

2.	Despotic leadership Is in charge and does not tolerate disagreement or questioning, gives orders	1	2	3	4	5
3.	Despotic leadership Acts like a tyrant or despot; imperious	1	2	3	4	5
4.	Despotic leadership Tends to be unwilling or unable to relinquish control of projects or tasks	1	2	3	4	5

5.	Despotic leadership Expects unquestioning obedience of those who report to him/her	1	2	3	4	5
6.	Despotic leadership Is vengeful; seeks revenge when wronged	1	2	3	4	5

## Section B: Deviant Workplace Behaviors

Please indicate the number of times in the last year you had engaged in the behavior described below.

S. No.	Statements	Never	Several Times a Year	Monthly	Weekly	Daily
1.	Taken property from work without permission	1	2	3	4	5
2.	Spent too much time fantasizing or daydreaming instead of working	1	2	3	4	5
3.	Falsified a receipt to get reimbursed for more money than you spent on business expenses	1	2	3	4	5

---

4.	Taken an additional or longer break than is acceptable at your workplace	1	2	3	4	5
5.	Come in late to work without permission	1	2	3	4	5
6.	Littered your work environment	1	2	3	4	5
7.	Neglected to follow your boss's instructions	1	2	3	4	5
8.	Intentionally worked slower than you could have worked	1	2	3	4	5
9.	Used an illegal drug or consumed alcohol on the job	1	2	3	4	5
10.	Put little effort into your work	1	2	3	4	5
11.	Dragged out work in order to get overtime	1	2	3	4	5
12.	Discussed confidential company information with an unauthorized person	1	2	3	4	5

## Section C: Trait Anxiety

Please tick the relevant choice.

S. No.	Statements	Strongly Disagree	Disagree	Neutral	Agree	Strongly Agree
1.	I picture some future misfortune	1	2	3	4	5
2.	I can't get some thoughts out of my head	1	2	3	4	5
3.	I keep busy to avoid uncomfortable thoughts	1	2	3	4	5
4.	I have to be careful not to let my real feeling show	1	2	3	4	5

## Section D: Personal Profile

Please provide the following information.

	1	2	3	4	5
Gender:	Male	Female			
Age:	20-30	31-40	41-50	51 and above	
Qualification	Inter	Bachelor	Master	MS	Ph.D
Experience	5-10	11-15	16-20	21-25	26 and above